



DECLARATION OF PERFORMANCE



No. 0078 – EN

1. Unique identification code of the product-type: **fischer concrete screw ULTRACUT FBS II**

2. Intended use/es:

| Product | Intended use/es |
|---|---|
| Metal anchors for use in concrete (heavy-duty type) | For fixing and/or supporting concrete structural elements or heavy units such as cladding and suspended ceilings, see appendix, especially Annexes B 1 to B 4 |

3. Manufacturer: **fischerwerke GmbH & Co. KG, Klaus-Fischer-Straße 1, 72178 Waldachtal, Germany**

4. Authorised representative: --

5. System/s of AVCP: **1**

6a. Harmonised standard: ---

Notified body/ies: ---

6b. European Assessment Document: **ETAG 001; 2013-04**

EAD 330011-00-0601; 2014-07

European Technical Assessment: **ETA-15/0352; 2016-04-12**

Technical Assessment Body: **DIBt**

Notified body/ies: **1343 – MPA Darmstadt**

7. Declared performance/s:

Mechanical resistance and stability (BWR 1)

| Essential characteristic | Performance |
|--|------------------------------------|
| Characteristic values for resistance for static and quasi-static loads | See appendix, especially Annex C 1 |
| Characteristic resistance for seismic performance categories C1 and C2 | See appendix, especially Annex C 2 |
| Displacements for tension and shear loads | See appendix, especially Annex C 4 |

Safety in case of fire (BWR 2)

| Essential characteristic | Performance |
|--------------------------|--|
| Reaction to fire | Anchorage satisfy requirements for Class A 1 |
| Resistance to fire | See appendix, especially Annex C 3 |

8. Appropriate Technical Documentation and/or Specific Technical Documentation: ---

The performance of the product identified above is in conformity with the set of declared performance/s. This declaration of performance is issued, in accordance with Regulation (EU) No 305/2011, under the sole responsibility of the manufacturer identified above.

Signed for and on behalf of the manufacturer by:

Andreas Bucher, Dipl.-Ing.

Wolfgang Hengesbach, Dipl.-Ing., Dipl.-Wirtsch.-Ing.

Tumlingen, 2016-04-19

- This DoP has been prepared in different languages. In case there is a dispute on the interpretation the english version shall always prevail.

- The Appendix includes voluntary and complementary information in English language exceeding the (language-neutrally specified) legal requirements.

Specific Part

1 Technical description of the product

The fischer concrete screw ULTRACUT FBS II is an anchor made of hardened carbon steel of sizes 8, 10, 12 and 14. The anchor is screwed into a predrilled cylindrical drill hole. The special thread of the anchor cuts an internal thread into the member while setting. The anchorage is characterised by mechanical interlock in the special thread.

The product description is given in Annex A.

2 Specification of the intended use in accordance with the applicable European Assessment Document

The performances given in Section 3 are only valid if the anchor is used in compliance with the specifications and conditions given in Annex B.

The verifications and assessment methods on which this European Technical Assessment is based lead to the assumption of a working life of the anchor of at least 50 years. The indications given on the working life cannot be interpreted as a guarantee given by the producer, but are to be regarded only as a means for choosing the right products in relation to the expected economically reasonable working life of the works.

3 Performance of the product and references to the methods used for its assessment

3.1 Mechanical resistance and stability (BWR 1)

| Essential characteristic | Performance |
|--|---------------|
| Characteristic values for resistance for static and quasi-static loads | See Annex C 1 |
| Characteristic resistance for seismic performance categories C1 and C2 | See Annex C 2 |
| Displacements for tension and shear loads | See Annex C 4 |

3.2 Safety in case of fire (BWR 2)

| Essential characteristic | Performance |
|--------------------------|---|
| Reaction to fire | Anchorage satisfy requirements for Class A1 |
| Resistance to fire | See Annex C 3 |

3.3 Safety in use (BWR 4)

For Basic Works Requirement Safety in use the same criteria are valid as for Basic Works Requirement Mechanical resistance and stability.

4 Assessment and verification of constancy of performance (AVCP) system applied, with reference to its legal base

In accordance with guideline for European technical approval ETAG 001, April 2013, used as European Assessment Document (EAD) according to Article 66 Paragraph 3 of Regulation (EU) No 305/2011, and European Assessment Document EAD 330011-00-0601 the applicable European legal act is: [96/582/EC].

The system to be applied is: 1

Product in the installed condition

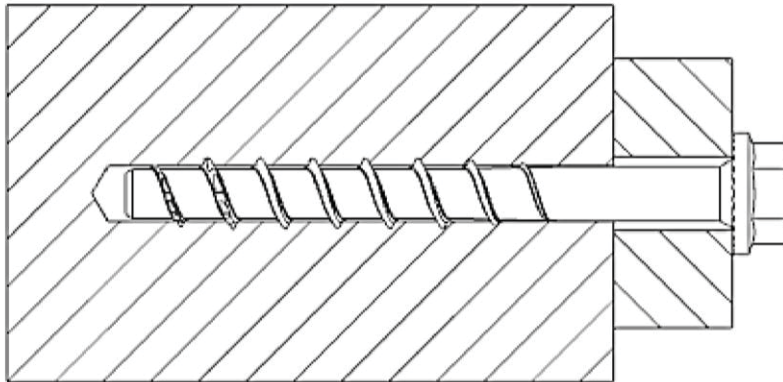

FBS II US

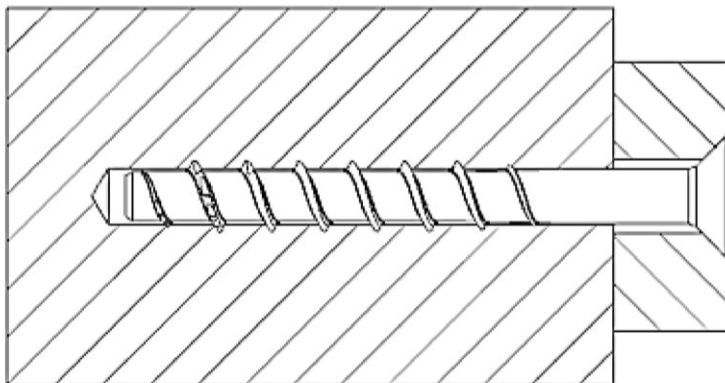

FBS II SK

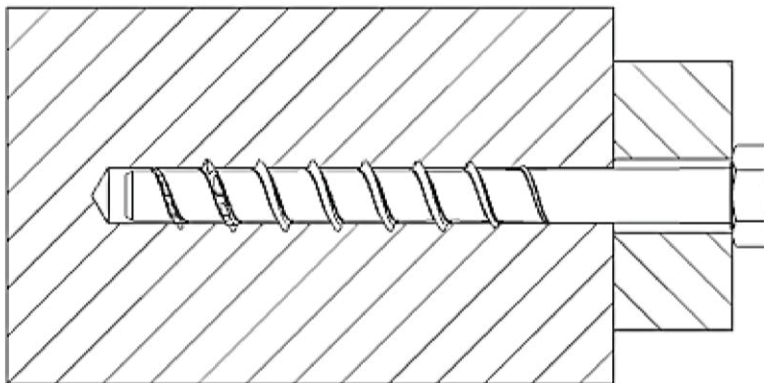







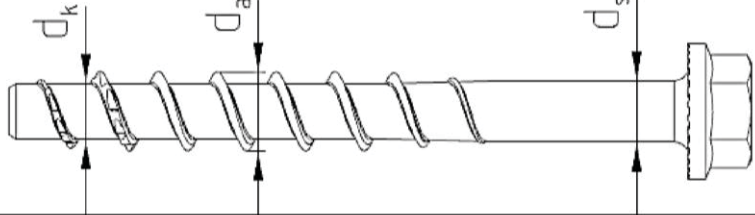

FBS II S

fischer concrete screw ULTRACUT FBS II

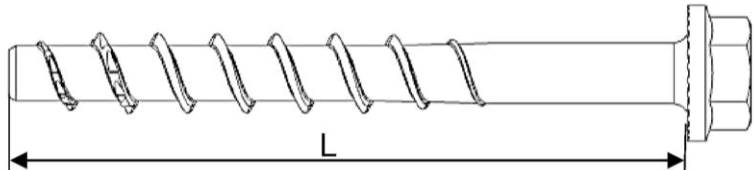
Product description
Product in the installed condition

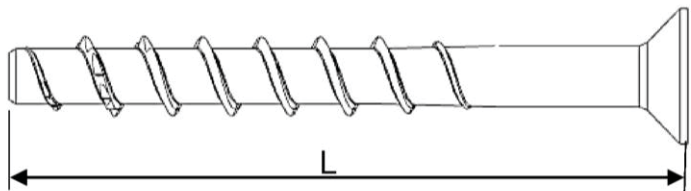
Annex A 1

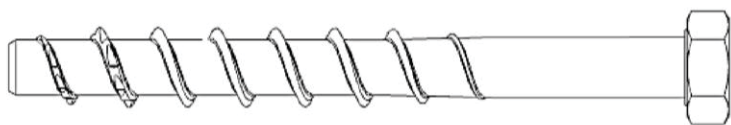
Table A1: Material and screw types

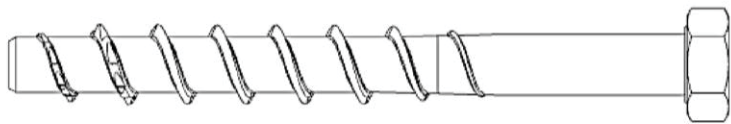
| Type of screw / size | | | FBS II US / SK / S | | | |
|---|---|--|---|------|------|------|
| | | | 8 | 10 | 12 | 14 |
| Thread outer diameter | d_a | [mm] | 10,3 | 12,5 | 14,5 | 16,6 |
| Core diameter | d_k | [mm] | 7,4 | 9,4 | 11,3 | 13,3 |
| Shaft diameter | d_s | [mm] | 8,0 | 9,9 | 11,7 | 13,7 |
| Material | | | Hardened carbon steel; $A_{5\%} \geq 8\%$ | | | |
| Coating | | | Zinc plated | | | |
| Hexagon head with formed washer (US) |  |  | | | | |
| Hexagon head with formed washer (US TX) |  |  | | | | |
| Countersunk Head (SK) |  |  | | | | |
| Hexagon Head (S) |  |  | | | | |
| Hexagon Head (S TX) |  |  | | | | |

Head Marking



FBS II: Product description

10: screw size

XXX: screw length

fischer concrete screw ULTRACUT FBS II

Product description
Material and screw types

Annex A 2

Specifications of intended use

Anchorage subject to:

- Static and quasi-static loads: All sizes and all embedment depths
- Seismic action for Seismic Performance Category C1 and C2: Only for maximum h_{nom} .
- Fire exposure: all sizes and all embedment depths according to Annex C3.

Base materials:

- Reinforced and unreinforced normal weight concrete according to EN 206:2013
- Strength classes C20/25 to C50/60 according to EN 206:2013
- Non-cracked or cracked concrete: All sizes and all embedment depths

Use conditions (Environmental conditions):

- Structures subject to dry internal conditions.

Design:

- Anchorages are to be designed under the responsibility of an engineer experienced in anchorages and concrete work.
- Verifiable calculation notes and drawings are to be prepared taking account of the loads to be anchored. The position of the screw is indicated on the design drawings (e.g. position of the screw relative to reinforcement or to supports, etc.).
- Anchorages under static or quasi-static actions are to be designed in accordance with:
 - ETAG 001, Annex C, design method A, Edition August 2010 or
 - CEN/TS 1992-4:2009, design method A
- Anchorages under seismic actions are to be designed in accordance with:
 - EOTA Technical Report TR 045, Edition February 2013
 - Anchorages shall be positioned outside of critical regions (e.g. plastic hinges) of the concrete structure.
 - Fastenings in stand-off installation or with a grout layer under seismic action are not allowed.
- Anchorages under fire exposure are to be designed in accordance with:
 - EOTA Technical Report TR 020, Edition May 2004 or
 - CEN/TS 1992-4:2009, Annex D
 - It must be ensured that local spalling of the concrete cover does not occur.

Installation:

- Hammer drilling or diamond drilling or hollow drilling according to Annex B4: All sizes and all embedment depths.
- Screw installation carried out by appropriately qualified personnel and under the supervision of the person responsible for technical matters on site.
- In case of aborted hole: New hole must be drilled at a minimum distance of twice the depth of the aborted hole or closer, if the hole is filled with a high strength mortar and only if the hole is not in the direction of the oblique tensile or shear load.
- Adjustability according to Annex B3 for: All sizes and all embedment depths.
- Cleaning of drill hole is not necessary when using a hollow drill or:
 - If drilling vertically upwards
 - If drilling vertical downwards and the drill hole depth has been increased. We recommend to increase the drill depth with additional $3 d_0$.
- After correct installation further turning of the screw head should not be possible
- The head of the screw must be fully engaged on the fixture and show no signs of damage.
- For Seismic Performance Category C2 applications: The gap between screw shaft and fixture must be filled with mortar; compressive strength $\geq 50 \text{ N/mm}^2$ (for example FIS V, FIS EM, FIS HB or FIS SB).

fischer concrete screw ULTRACUT FBS II

Intended Use
Specifications

Annex B 1

Table B1: Installation parameters

| screw size | | | FBS II | | | | | | | | | | |
|--|---------------------|------|---------------|-----|---------------|-----|-----|---------------|-----|-----|---------------|-----|-----|
| | | | 8 | | 10 | | | 12 | | | 14 | | |
| Nominal embedment depth | h_{nom} | [mm] | 50 | 65 | 55 | 65 | 85 | 60 | 75 | 100 | 65 | 85 | 115 |
| Nominal drill hole diameter | d_0 | [mm] | 8 | | 10 | | | 12 | | | 14 | | |
| Cutting diameter of drill bits | $d_{cut} \leq$ | [mm] | 8,45 | | 10,45 | | | 12,50 | | | 14,50 | | |
| Cutting diameter tolerance especially for diamond drillers | d_{cut} | [mm] | 8,05 - 8,45 | | 10,05 - 10,45 | | | 12,10 - 12,50 | | | 14,10 - 14,50 | | |
| Clearance hole diameter | d_f | [mm] | 10,6 - 12,0 | | 12,8 - 14,0 | | | 14,8 - 16,0 | | | 16,9 - 18,0 | | |
| Wrench size (US,S) | SW | [mm] | 13 | | 15 | | | 17 | | | 21 | | |
| Tx size | Tx | - | 40 | | 50 | | | - | | | - | | |
| Countersunk head diameter | d_h | [mm] | 18 | | 21 | | | - | | | - | | |
| Countersunk diameter in fixture | d_c | [mm] | 20 | | 23 | | | - | | | - | | |
| Drill hole depth ¹⁾ | $h_1 \geq$ | [mm] | 60 | 75 | 65 | 75 | 95 | 70 | 85 | 110 | 80 | 100 | 130 |
| Drill hole depth ¹⁾ (with adjustable setting process) | $h_1 \geq$ | [mm] | 70 | 85 | 75 | 85 | 105 | 80 | 95 | 120 | 90 | 110 | 140 |
| Thickness of fixture | $t_{fix}^{3)} \geq$ | [mm] | 0 | | | | | | | | | | |
| | $t_{fix} \leq$ | [mm] | L - h_{nom} | | | | | | | | | | |
| Length of screw | $L_{min}^{3)} =$ | [mm] | 50 | 65 | 55 | 65 | 85 | 60 | 75 | 100 | 65 | 85 | 115 |
| | $L_{max} =$ | [mm] | 400 | 415 | 405 | 415 | 435 | 410 | 425 | 450 | 415 | 435 | 465 |
| Torque impact screw driver ²⁾ | $T_{imp,max}$ | [Nm] | 600 | | 650 | | | | | | | | |

1) Cleaning of drill hole is not necessary when using a hollow drill or:

- if drilling vertical upwards
- If drilling vertical downwards and the drill hole depth has been increased. We recommend to increase the drill depth with additional 3 d_0 .

2) Installation with any torque impact screw driver up to the maximum mentioned torque moment ($T_{imp,max}$). Alternatively, all other tools without a mentioned torque moment are allowed (e.g. ratchet spanner). In any case it must be secured, that after installation the head of the screw must be tight down on the fixture. An easy further turning of the screw must not be possible and the head of the screw is not damaged. The torque moments $T_{imp,max}$ are not valid for manual installation (e.g. torque wrench).

3) For countersunk screws the height of the head must be added to t_{fix} and L_{min} .

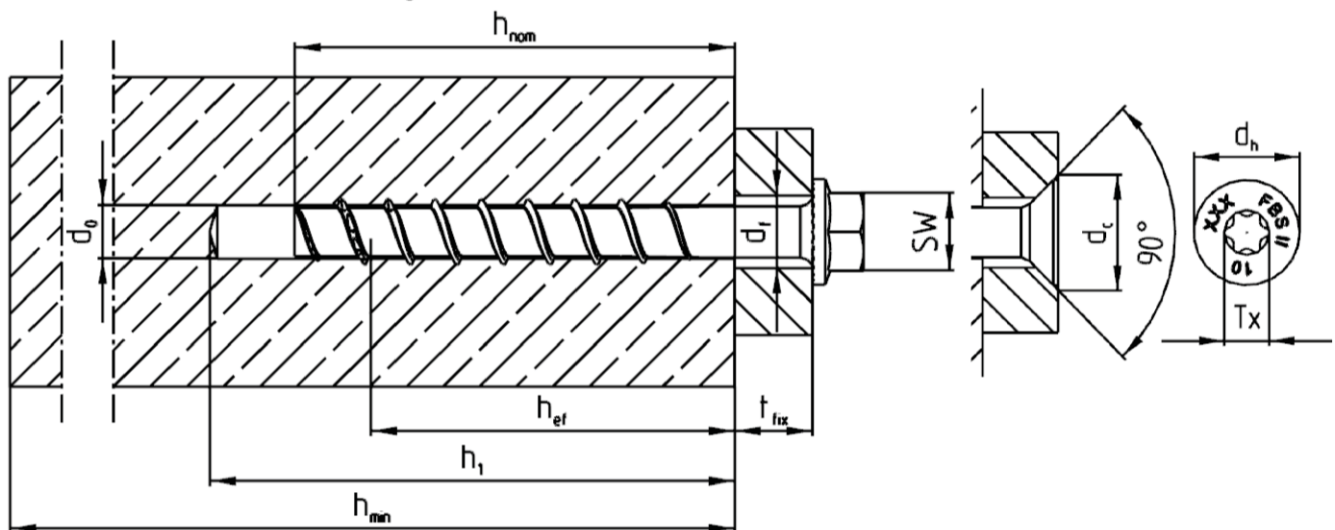

fischer concrete screw ULTRACUT FBS II

Intended Use
Installation parameters

Annex B 2

Adjustment

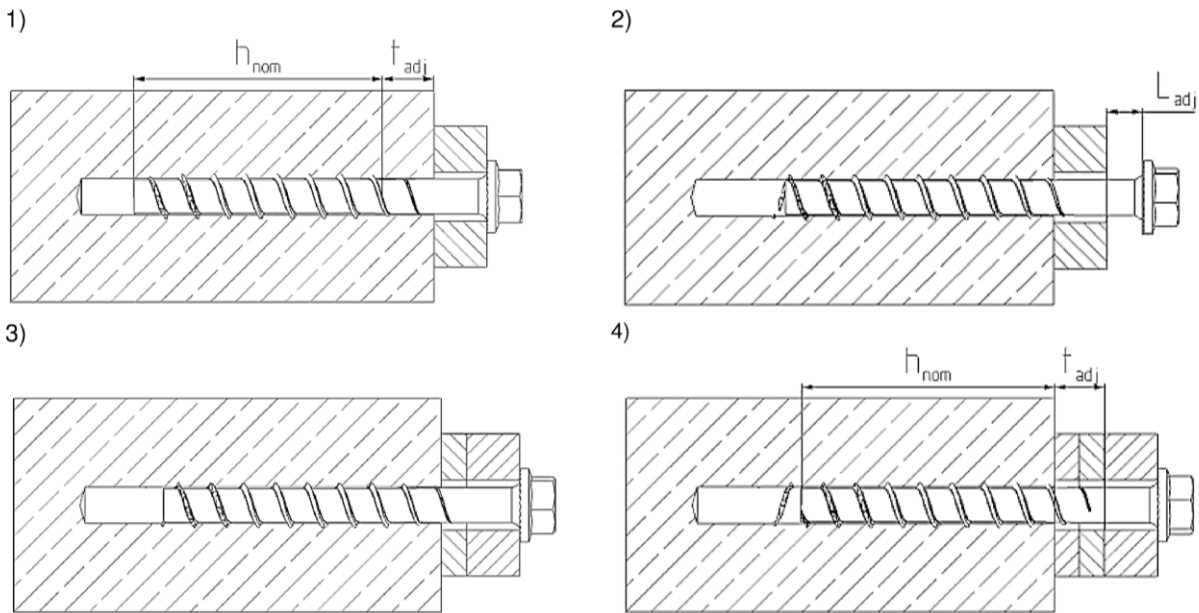

It is permissible to untighten the screw up to two times for adjustment purposes.
 Therefore the screw may be untightened to a maximum
 of $L_{adj} = 20$ mm off the surface of the initial fixture.
 The total permissible thickness of shims added during the adjustment process is $t_{adj} = 10$ mm.

Table B3: Minimum thickness of concrete members, minimum spacing and edge distance

| Screw size | | | FBS II | | | | | | | | | | |
|--------------------------------------|-----------|------|--------|-----|-----|-----|-----|-----|-----|-----|-----|-----|-----|
| | | | 8 | | 10 | | | 12 | | | 14 | | |
| Nominal embedment depth | h_{nom} | [mm] | 50 | 65 | 55 | 65 | 85 | 60 | 75 | 100 | 65 | 85 | 115 |
| Minimum thickness of concrete member | h_{min} | [mm] | 100 | 120 | 100 | 120 | 140 | 110 | 130 | 150 | 120 | 140 | 180 |
| Minimum spacing | s_{min} | [mm] | 35 | | 40 | | | 50 | | | 60 | | |
| Minimum edge distance | c_{min} | [mm] | 35 | | 40 | | | 50 | | | 60 | | |

fischer concrete screw ULTRACUT FBS II

Intended Use
 Adjustment
 Minimum thickness of concrete members, minimum spacing and edge distance

Annex B 3





| Installation instruction | | |
|---|--|--|
|  | | <p>Drill the hole using hammer drill, hollow drill or diamond core drill.</p> <p>Drill hole diameter d_0 and drill hole depth h_1 according to table B1</p> |
| <p>a) </p> <p>b)  </p> | | <p>Option a) Clean the drill hole</p> <p>Option b) Cleaning of drill hole is not necessary when using a hollow drill or:</p> <ul style="list-style-type: none"> - If drilling vertically upwards or - If drilling vertically downwards and the drill hole depth has been increased. We recommend to increase the drill hole depth additional 3 times d_0. |
|   | | <p>Installation with any torque impact screw driver up to the maximum mentioned torque moment ($T_{imp,max}$). Alternatively, all other tools without an indicated torque moment are allowed (e.g. ratchet spanner). The indicated torque moments for impact screw driver are therefore not decisive.</p> |
|  | | <p>After installation a further turning of the screw must not be possible. The head of the screw must be supported on the fixture and is not damaged.</p> |
| <p>1. </p> <p>2. </p> <p>3. </p> | | <p>OPTIONAL: It is permissible to adjust the screw two times. Therefore the screw may be untighten to a maximum of $L_{adj} = 20$ mm off the surface of the initial fixture. The total permissible thickness of shims added during the adjustment process is $t_{adj} = 10$ mm</p> |
|  | | <p>For Seismic Performance Category C2 applications: The gap between screw shaft and fixture must be filled with mortar; compressive strength ≥ 50 N/mm² for example: FIS V, FIS EM, FIS HB or FIS SB.</p> |
| fischer concrete screw ULTRACUT FBS II | | Annex B 4 |
| Intended Use Installation instructions | | |

Table C1: Performance for static and quasi-static action

| Screw size | | | FBS II | | | | | | | | | | |
|---|--------------------------------------|----------------|--------|-----------------|------|-----|------|-----------------|-----------------|-----------------|-----------------|-----------------|-----------------|
| | | | 8 | | 10 | | | 12 | | | 14 | | |
| Nominal embedment depth | h_{nom} | [mm] | 50 | 65 | 55 | 65 | 85 | 60 | 75 | 100 | 65 | 85 | 115 |
| Steel failure for tension load and shear load | | | | | | | | | | | | | |
| Characteristic resistance | $N_{Rk,S}$ | [kN] | 35 | | 55 | | | 76 | | | 103 | | |
| | $\gamma_{M,S,N}$ | [kN] | 1,4 | | | | | | | | | | |
| | $V_{Rk,S}$ | [kN] | 13,1 | 19,0 | 29,4 | | 34,9 | 31,9 | | 42,7 | 46,5 | | 61,7 |
| | $\gamma_{M,S,V}$ | [-] | 1,5 | | | | | | | | | | |
| | $k_2^{2)}$ | [-] | 1,0 | | | | | | | | | | |
| | $M^0_{Rk,s}$ | [Nm] | 51 | | 95 | | | 165 | | | 269 | | |
| Pullout failure | | | | | | | | | | | | | |
| Charact. resistance in concrete C20/25 | Cracked | $N_{Rk,P}$ | [kN] | 6 | 12 | 9 | 12 | - ¹⁾ | - ¹⁾ | - ¹⁾ | - ¹⁾ | - ¹⁾ | - ¹⁾ |
| | Non-cracked | $N_{Rk,P}$ | [kN] | - ¹⁾ | | | | | | | | | |
| Increasing factor concrete | C25/30 | ψ_c | [-] | 1,10 | | | | | | | | | |
| | C30/37 | | | 1,22 | | | | | | | | | |
| | C35/45 | | | 1,34 | | | | | | | | | |
| | C40/50 | | | 1,41 | | | | | | | | | |
| | C45/55 | | | 1,48 | | | | | | | | | |
| | C50/60 | | | 1,55 | | | | | | | | | |
| Installation safety factor | $\gamma_2 = \gamma_{inst}$ | [-] | 1,0 | | | | | | | | | | |
| Concrete cone failure and splitting failure; Concrete pryout failure | | | | | | | | | | | | | |
| Effective embedment depth | h_{ef} | [mm] | 40 | 52 | 43 | 51 | 68 | 47 | 60 | 81 | 50 | 67 | 93 |
| Factor for | Cracked | $k_{cr}^{2)}$ | [mm] | 7,2 | | | | | | | | | |
| | Non-cracked | $k_{ucr}^{2)}$ | [mm] | 10,1 | | | | | | | | | |
| Concrete cone failure | Edge distance | $c_{cr,N}$ | [mm] | 1,5 h_{ef} | | | | | | | | | |
| | Spacing | $s_{cr,N}$ | [mm] | 3 h_{ef} | | | | | | | | | |
| Splitting failure | Edge distance | $c_{cr,sp}$ | [mm] | 1,5 h_{ef} | | | | | | | | | |
| | Spacing | $s_{cr,sp}$ | [mm] | 3 h_{ef} | | | | | | | | | |
| k-factor for pryout failure | $k^{3)} = k_3^{2)}$ | [-] | 1,0 | 2,0 | 1,0 | 2,0 | | | | | | | |
| Installation safety factor | $\gamma_2^{3)} = \gamma_{inst}^{2)}$ | [-] | 1,0 | | | | | | | | | | |
| Concrete edge failure | | | | | | | | | | | | | |
| Effective length in concrete | $l_f = h_{nom}$ | [mm] | 50 | 65 | 55 | 65 | 85 | 60 | 75 | 100 | 65 | 85 | 115 |
| Nominal diameter of screw | d_{nom} | [mm] | 8 | | 10 | | | 12 | | | 14 | | |
| Adjustment | | | | | | | | | | | | | |
| max. thickness of adjustment layers | t_{adj} | [mm] | 10 | | | | | | | | | | |
| Max. number of adjustments | n_a | [-] | 2 | | | | | | | | | | |

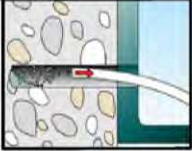
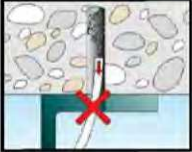
1) Pullout failure not decisive.
 2) Parameters relevant only for design according to CEN/TS 1992-4:2009
 3) Parameters relevant only for design according to ETAG 001 Annex C

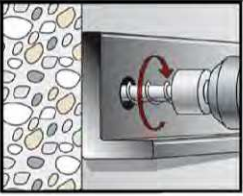
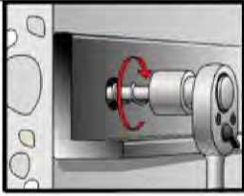
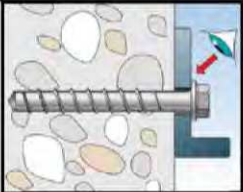
fischer concrete screw ULTRACUT FBS II

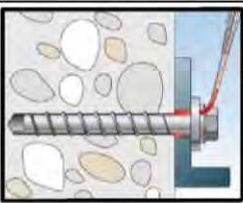
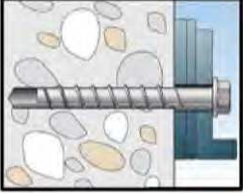
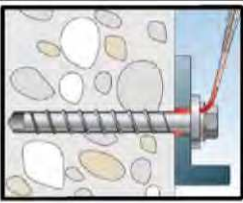
Performances
 Performance for static and quasi-static action

Annex C 1

Table C2: Characteristic values for Seismic Performance Category C1

| Screw size | | | FBS II | | | |
|---|-----------------|------------|--------------|-----------------|------|------|
| | | | 8 | 10 | 12 | 14 |
| Nominal embedment depth | h_{nom} | [mm] | 65 | 85 | 100 | 115 |
| Steel failure for tension load and shear load C1 | | | | | | |
| Characteristic resistance | $N_{Rk,S,C1}$ | [kN] | 35 | 55 | 76 | 103 |
| | $V_{Rk,S,C1}$ | [kN] | 11,4 | 22,3 | 26,9 | 38,3 |
| Pullout failure | | | | | | |
| Characteristic resistance in cracked concrete | $N_{Rk,p,C1}$ | [kN] | 12 | - ¹⁾ | | |
| Concrete cone failure | | | | | | |
| Effective embedment depth | h_{ef} | [mm] | 52 | 68 | 81 | 93 |
| Concrete cone failure | Edge distance | $c_{cr,n}$ | 1,5 h_{ef} | | | |
| | Spacing | $s_{cr,n}$ | 3 h_{ef} | | | |
| Installation safety factor | γ_2 | [-] | 1,0 | | | |
| Concrete pryout failure | | | | | | |
| k-factor | k | [-] | 2,0 | | | |
| Concrete edge failure | | | | | | |
| Effective length in concrete | $l_f = h_{nom}$ | [mm] | 65 | 85 | 100 | 115 |
| Nominal diameter of screw | d_{nom} | [mm] | 8 | 10 | 12 | 14 |

Table C3: Characteristic values for Seismic Performance Category C2

Gap between screw shaft and fixture must be filled with mortar

| Screw size | | | FBS II | | | |
|---|-----------------|------------|--------------|------|------|------|
| | | | 8 | 10 | 12 | 14 |
| Nominal embedment depth | h_{nom} | [mm] | 65 | 85 | 100 | 115 |
| Steel failure for tension load and shear load C2 | | | | | | |
| Characteristic resistance | $N_{Rk,S,C2}$ | [kN] | 35,0 | 55 | 76,0 | 103 |
| | $V_{Rk,S,C2}$ | [kN] | 13,3 | 20,4 | 29,9 | 35,2 |
| Pullout failure | | | | | | |
| Characteristic resistance in cracked concrete | $N_{Rk,p,C2}$ | [kN] | 2,1 | 6,0 | 8,9 | 17,1 |
| Concrete cone failure | | | | | | |
| Effective embedment depth | h_{ef} | [mm] | 52 | 68 | 81 | 93 |
| Concrete cone failure | Edge distance | $c_{cr,n}$ | 1,5 h_{ef} | | | |
| | Spacing | $s_{cr,n}$ | 3 h_{ef} | | | |
| Installation safety factor | γ_2 | [-] | 1,0 | | | |
| Concrete pryout failure | | | | | | |
| k-factor | k | [-] | 2,0 | | | |
| Concrete edge failure | | | | | | |
| Effective length in concrete | $l_f = h_{nom}$ | [mm] | 65 | 85 | 100 | 115 |
| Nominal diameter of screw | d_{nom} | [mm] | 8 | 10 | 12 | 14 |

¹⁾ Pullout failure not decisive.

fischer concrete screw ULTRACUT FBS II

Performances
 Characteristic values for Seismic Performance Category C1 and C2

Annex C 2

Table C4: Characteristic values for resistance to fire

| Screw size | | | | FBS II | | | | | | | | | | | |
|---|-----------------------|---------------|-----------------|---------------|------|-----|------|-----|-----|------|------|-----|-------|------|--|
| Minimum embedment depth | | | | 8 | | 10 | | | 12 | | | 14 | | | |
| | | h_{nom} | [mm] | 50 | 65 | 55 | 65 | 85 | 60 | 75 | 100 | 65 | 85 | 115 | |
| Steel failure for tension load and shear load ($F_{Rk,s,fi} = N_{Rk,s,fi} = V_{Rk,s,fi}$) | | | | | | | | | | | | | | | |
| Characteristic resistance for head shape | US, S | R30 | $F_{Rk,s,fi}$ | [kN] | 2,33 | | 3,45 | | | 4,62 | | | 6,46 | | |
| | | R60 | $F_{Rk,s,fi}$ | [kN] | 1,82 | | 2,73 | | | 3,66 | | | 5,11 | | |
| | | R90 | $F_{Rk,s,fi}$ | [kN] | 1,30 | | 2,00 | | | 2,69 | | | 3,75 | | |
| | | R120 | $F_{Rk,s,fi}$ | [kN] | 1,04 | | 1,64 | | | 2,20 | | | 3,08 | | |
| | SK, US TX, S TX | R30 | $F_{Rk,s,fi}$ | [kN] | 2,12 | | 2,96 | | | - | | | - | | |
| | | R60 | $F_{Rk,s,fi}$ | [kN] | 1,67 | | 2,26 | | | - | | | - | | |
| | | R90 | $F_{Rk,s,fi}$ | [kN] | 1,21 | | 1,56 | | | - | | | - | | |
| | | R120 | $F_{Rk,s,fi}$ | [kN] | 0,99 | | 1,21 | | | - | | | - | | |
| | All head shapes | R30 | $M^0_{Rk,s,fi}$ | [Nm] | 2,62 | | 4,92 | | | 7,83 | | | 12,89 | | |
| | | R60 | $M^0_{Rk,s,fi}$ | [Nm] | 2,05 | | 3,89 | | | 6,20 | | | 10,19 | | |
| | | R90 | $M^0_{Rk,s,fi}$ | [Nm] | 1,46 | | 2,85 | | | 4,56 | | | 7,48 | | |
| | | R120 | $M^0_{Rk,s,fi}$ | [Nm] | 1,17 | | 2,34 | | | 3,73 | | | 6,14 | | |
| Pullout failure | | | | | | | | | | | | | | | |
| Characteristic resistance | R30 | $N_{Rk,s,fi}$ | [kN] | | | | | | | | | | | | |
| | R60 | $N_{Rk,s,fi}$ | [kN] | 1,5 | 3,0 | 2,3 | 3,0 | 5,0 | 2,9 | 4,2 | 6,6 | 3,2 | 4,9 | 8,1 | |
| | R90 | $N_{Rk,s,fi}$ | [kN] | | | | | | | | | | | | |
| | R120 | $N_{Rk,s,fi}$ | [kN] | 1,2 | 2,4 | 1,8 | 2,4 | 4,0 | 2,3 | 3,3 | 5,2 | 2,5 | 3,9 | 6,5 | |
| Concrete cone failure | | | | | | | | | | | | | | | |
| Characteristic resistance | R30 | $N_{Rk,s,fi}$ | [kN] | | | | | | | | | | | | |
| | R60 | $N_{Rk,s,fi}$ | [kN] | 1,7 | 3,5 | 2,2 | 3,3 | 6,9 | 2,7 | 5,0 | 10,6 | 3,2 | 6,6 | 15,0 | |
| | R90 | $N_{Rk,s,fi}$ | [kN] | | | | | | | | | | | | |
| | R120 | $N_{Rk,s,fi}$ | [kN] | 1,4 | 2,8 | 1,7 | 2,7 | 5,5 | 2,2 | 4,0 | 8,5 | 2,5 | 5,3 | 12,0 | |
| Edge distance | | | | | | | | | | | | | | | |
| R30 to R120 | | $C_{cr,fi}$ | [mm] | 2 h_{ef} | | | | | | | | | | | |
| In case of fire attack from more than one side, the minimum edge distance shall be ≥ 300 mm | | | | | | | | | | | | | | | |
| Spacing | | | | | | | | | | | | | | | |
| R30 to R120 | | $S_{cr,fi}$ | [mm] | 2 $C_{cr,fi}$ | | | | | | | | | | | |
| Concrete pryout failure | | | | | | | | | | | | | | | |
| R30 to R120 | | k | [-] | 1,0 | 2,0 | 1,0 | 2,0 | | | | | | | | |
| The anchorage depth has to be increased for wet concrete by at least 30 mm compared to the given value | | | | | | | | | | | | | | | |

fischer concrete screw ULTRACUT FBS II

Performances:
Characteristic values for resistance to fire

Annex C 3

Table C5: Displacements due to tension loads (static)

| Screw size | | | FBS II | | | | | | | | | | |
|--|--------------------|------|--------|------|-----|-----|------|-----|------|------|-----|------|------|
| | | | 8 | | 10 | | | 12 | | | 14 | | |
| Nominal embedment depth | h_{nom} | [mm] | 50 | 65 | 55 | 65 | 85 | 60 | 75 | 100 | 65 | 85 | 115 |
| Tension load in cracked concrete | N | [kN] | 2,9 | 5,7 | 4,3 | 5,7 | 9,6 | 5,5 | 8,0 | 12,5 | 6,1 | 9,4 | 15,3 |
| Displacement | δ_{N0} | [mm] | 0,5 | 0,9 | 0,7 | 0,7 | 0,8 | 0,7 | 0,9 | 0,8 | 0,8 | 1,0 | 0,8 |
| | $\delta_{N\infty}$ | [mm] | 1,3 | 1,0 | 0,7 | 0,7 | 0,8 | 1,3 | 0,9 | 0,8 | 1,1 | 1,0 | 1,1 |
| Tension load in non - cracked concrete | N | [kN] | 7,9 | 12,0 | 6,8 | 8,8 | 13,5 | 7,7 | 11,0 | 17,4 | 8,5 | 13,2 | 21,6 |
| Displacement | δ_{N0} | [mm] | 0,9 | 1,4 | 0,9 | 0,9 | 1,4 | 0,9 | 1,1 | 1,4 | 1,0 | 1,3 | 1,1 |
| | $\delta_{N\infty}$ | [mm] | 1,4 | 1,4 | 1,4 | 1,4 | 1,4 | 1,4 | 1,4 | 1,4 | 1,1 | 1,3 | 1,1 |

Table C6: Displacements due to shear loads (static)

| Screw size | | | FBS II | | | | | | | | | | |
|--|--------------------|------|--------|-----|------|------|------|------|------|------|------|------|------|
| | | | 8 | | 10 | | | 12 | | | 14 | | |
| Nominal embedment depth | h_{nom} | [mm] | 50 | 65 | 55 | 65 | 85 | 60 | 75 | 100 | 65 | 85 | 115 |
| Shear load in cracked and non-cracked concrete | V | [kN] | 6,2 | 9,0 | 14,0 | 14,0 | 16,6 | 15,9 | 15,9 | 21,2 | 23,0 | 23,0 | 30,5 |
| Displacement | δ_{V0} | [mm] | 1,4 | 1,4 | 3,2 | 3,2 | 3,2 | 2,5 | 2,5 | 3,4 | 2,8 | 2,8 | 5,4 |
| | $\delta_{V\infty}$ | [mm] | 2,0 | 2,1 | 4,9 | 4,9 | 4,9 | 3,8 | 3,8 | 5,1 | 4,2 | 4,2 | 8,1 |

Table C7: Displacements due to tension loads (Seismic Performance Category C2)

| Screw size | | | FBS II | | | | | | | | | | |
|-------------------------|----------------------|------|--------|--|-----|--|--|-----|--|--|-----|--|--|
| | | | 8 | | 10 | | | 12 | | | 14 | | |
| Nominal embedment depth | h_{nom} | [mm] | 65 | | 85 | | | 100 | | | 115 | | |
| Displacement DLS | $\delta_{N,C2(DLS)}$ | [mm] | 0,5 | | 0,8 | | | 0,9 | | | 1,3 | | |
| Displacement ULS | $\delta_{N,C2(ULS)}$ | [mm] | 1,7 | | 2,8 | | | 2,7 | | | 5,0 | | |

Table C8: Displacements due to shear loads (Seismic Performance Category C2)

| Screw size | | | FBS II | | | | | | | | | | |
|-------------------------|----------------------|------|--------|--|-----|--|--|-----|--|--|-----|--|--|
| | | | 8 | | 10 | | | 12 | | | 14 | | |
| Nominal embedment depth | h_{nom} | [mm] | 65 | | 85 | | | 100 | | | 115 | | |
| Displacement DLS | $\delta_{V,C2(DLS)}$ | [mm] | 1,6 | | 2,7 | | | 3,1 | | | 4,1 | | |
| Displacement ULS | $\delta_{V,C2(ULS)}$ | [mm] | 3,9 | | 7,1 | | | 5,3 | | | 8,7 | | |

fischer concrete screw ULTRACUT FBS II

Performances:
Displacements under tension and shear loads

Annex C 4