



ETA-Danmark A/S
Kollegievej 6
DK-2920 Charlottenlund
Tel. +45 72 24 59 00
Fax +45 72 24 59 04
Internet www.etadanmark.dk

Authorised and notified according
to Article 29 of the Regulation (EU)
No 305/2011 of the European
Parliament and of the Council of 9
March 2011

MEMBER OF EOTA



European Technical Assessment ETA-14/0160 of 26/06/2014

General Part

Technical Assessment Body issuing the ETA and designated according to Article 29 of the Regulation (EU) No 305/2011: ETA-Danmark A/S

Trade name of the
construction product:

IdeFix, ZaFix, bases

Product family to which the
above construction product
belongs:

Three-dimensional nailing plate (timber to timber
connectors)

Manufacturer:

SIHGA Handels GmbH
Gewerbepark Kleinreith 4
A-4694 Ohlsdorf
Tel. +49 7612 / 74370 - 0
Fax +49 7612 / 74370 - 10
Internet www.sihga.com

Manufacturing plant:

SIHGA Handels GmbH
Gewerbepark Kleinreith 4
A-4694 Ohlsdorf

This European Technical
Assessment contains:

43 pages including 4 annexes which form an integral
part of the document

This European Technical
Assessment is issued in
accordance with Regulation
(EU) No 305/2011, on the
basis of:

Guideline for European Technical Approval (ETAG) No.
015 Three Dimensional Nailing Plates, April 2013, used
as European Assessment Document (EAD).

This version replaces:

-

Translations of this European Technical Assessment in other languages shall fully correspond to the original issued document and should be identified as such.

Communication of this European Technical Assessment, including transmission by electronic means, shall be in full (excepted the confidential Annex(es) referred to above). However, partial reproduction may be made, with the written consent of the issuing Technical Assessment Body. Any partial reproduction has to be identified as such

II SPECIFIC PART OF THE EUROPEAN TECHNICAL ASSESSMENT

1 Technical description of product and intended use

Technical description of the product

IdeFix IF connectors are used in timber to timber connections.

IdeFix IFS connector is used for a steel cable - timber connection, mainly for transportation.

IdeFix IF and IFS connectors are assembled of a cylindrical part made of steel 1.0715 according to EN 10087 and self-tapping screws GoFix HK with properties assessed in ETA-11/0425.

ZaFix are assembled of a threaded rod 1.0401 according to EN 10277 and a tube 1.0308 according to EN 10216 and EN 10305.

IdeFix IF and ZaFix connectors can be used as a kit assembled with a post-base.

Post-bases IdeFix STF and ZaFix STZ are assembled of steel parts made of 1.0038 according to EN 10025 (S235JR); washer nut DIN 6923, property class 8 according to EN 20898; threaded rod of 1.0401 according to EN 10277 (C15); counter nut ISO 4035 (DIN 439), property class 4 according to EN 20898; special screw 1.0715 according to EN 10087; tube 1.0308 according to EN 10216 and EN 10305 (E235).

Dimensions and typical installations are shown in annex A to D.

2 Specification of the intended use in accordance with the applicable EAD

The intended use of the connectors is for timber to timber connections as load-bearing elements, where requirements for mechanical resistance and stability and safety in use in the sense of the Basic Work Requirements 1 and 4 of the Regulation 305/2011 (EU) shall be fulfilled.

IdeFix IF is mainly used as header - joist connection. It might be used as beam – column connector too. The connector is loaded in tension or by shearing forces, compression loads are not transmitted by IdeFix IF but in contact between end-grain of joist and header's side-grain or column's end-grain and beam's side-grain respectively.

IdeFix IFS is intended to be used for bracing by ties. This connector is not applied in the end-grain. Properties of the eye bolt are not assessed within this ETA, verification has

to be done according to Eurocode 3.

ZaFix connector is used only as assembled kit with post base.

IdeFix STF and ZaFix STZ are post bases. The post-base lower part to the upper steel plate, which works as support to the timber column, is identical for both products. The connection to the timber column is either done by IdeFix IF or by ZaFix.

The connectors are used for timber joints designed according to Eurocode 5; assembled with post-bases the joint to the column is designed according to Eurocode 5 in addition some verifications of the post base have to be done according to Eurocode 3. IdeFix IF connectors are used for joints of timber or wood-based products.

The connectors can be installed as joint between wood based members such as:

- Structural solid softwood timber according to EN 14081,
- Softwood glulam according to EN 14080,
- Glued solid timber according to EN 14080,

Header–joist or column-beam connections with IdeFix IF and joints with IdeFix IF might additionally be used with

- Engineered wood products according to European Technical Approval if the ETA of the product includes provisions for the use of self-tapping screws and ring-connectors, the provisions of the ETA of the engineered wood product apply

The annexes state the formulas for the characteristic load-carrying capacities of the connections. The design of the connections shall be in accordance with Eurocode 3, Eurocode 5 or a similar national Code.

It is assumed that the forces acting on the connection are the following F_1, F_c, F_t and F_2, F_3, F_4, F_5, F_h . The force F_1 or F_c or F_t acts parallel to the axis of joist or column, F_2, F_3, F_4, F_5, F_h act perpendicular to the axis of joist or column. It is assumed that the forces are acting right at the end of the joist.

It is assumed that the header beam is prevented from rotating. If the header beam only has installed a connector on one side the eccentricity moment shall be considered where b_H is the header width. The same applies when the header has connections on both sides, but with vertical forces which differ more than 20%.

The connectors are intended for use in connections subject to static or quasi static loading.

The use of IdeFix-connectors assembled with screws GoFix HK made of carbon steel according to ETA-11/0425 is limited to service class 1 and 2.

IdeFix-connectors and post-bases assembled with screws GoFix HK made of stainless steel according to ETA-11/0425 and post-bases with ZaFix can additionally be used in service-class 3.

The fasteners (bolts and washers) to be used shall be made from suitable material.

The scope of the connectors regarding resistance to corrosion shall be defined according to national provisions that apply at the installation site considering environmental conditions and in conjunction with the admissible service conditions according to EN 1995-1-1 and the admissible corrosivity category as described and defined in EN ISO 12944-2

Assumed working life

The assumed intended working life of the connectors for the intended use is 50 years, provided that they are subject to appropriate use and maintenance.

The information on the working life should not be regarded as a guarantee provided by the manufacturer or ETA Danmark. An “assumed intended working life” means that it is expected that, when this working life has elapsed, the real working life may be, in normal use conditions, considerably longer without major degradation affecting the essential requirements.

3 Performance of the product and references to the methods used for its assessment

Characteristic	Assessment of characteristic
3.1 Mechanical resistance and stability (BWR 1)*)	
Characteristic load-carrying capacity	See Annex A to Annex D
Stiffness	See Annex A to Annex D
Ductility in cyclic testing	No performance determined
3.2 Safety in case of fire (BWR 2)	
Reaction to fire	The connectors are made from steel classified as Euroclass A1 in accordance with EN 1350-1 and EC decision 96/603/EC, amended by EC Decision 2000/605/EC
3.3 Hygiene, health and the environment (BWR 3)	
Influence on air quality	The product does not contain/release dangerous substances specified in TR 034, dated March 2012 *)
3.7 Sustainable use of natural resources (BWR 7)	No Performance Determined
3.8 General aspects related to the performance of the product	The connectors and post-bases have been assessed as having satisfactory durability and serviceability when used in timber structures using the soft-wood timber species described in Eurocode 5 and subject to the conditions defined by service class 1, 2 or 3 for IdeFix connections assembled with screws GoFix HK made of stainless steel according to ETA-11/0425. Kits using screws GoFix HK made of carbon steel according to ETA-11/0425 are limited to service class 1 and 2.
Identification	See Annex A, B and C

*) See additional information in section 3.9 – 3.12.

In addition to the specific clauses relating to dangerous substances contained in this European technical Assessment, there may be other requirements applicable to the products falling within its scope (e.g. transposed European legislation and national laws, regulations and administrative provisions). In order to meet the provisions of the Construction Products Regulation, these requirements need also to be complied with, when and where they apply.

3.9 Methods of verification

Safety principles and partial factors

The characteristic load-carrying capacities are based on the characteristic values of the connections with metal fasteners, the steel plates and the timber post.

In the case of timber failure or failure of the metal fasteners, the design values shall be calculated according to EN 1995-1-1 by dividing the characteristic values of the load-carrying capacities by different partial factors for the strength properties, and in addition multiplied with the coefficient k_{mod} .

In the case of steel failure, the design value shall be calculated according to EN 1993-1-1 by reducing the characteristic values of the load-carrying capacity with different partial factors.

The design value of the load-carrying capacity is the smaller value of all load-carrying capacities:

$$F_{Rd} = \min \left\{ \frac{k_{mod} \cdot F_{Rk,T}}{\gamma_{M,T}}, \frac{F_{Rk,S}}{\gamma_{M,S}} \right\}$$

Therefore, for timber failure or failure of the metal fasteners the load duration class and the service class are included. The different partial factors γ_M for steel or timber failure, respectively, are also correctly taken into account.

3.10 Mechanical resistance and stability

See Annex A to D for characteristic load-carrying capacities of the connectors and post-bases.

The characteristic capacities of the connectors are determined by calculation assisted by testing as described in the EOTA Guideline 015 clause 2.4.1. They should be used for designs in accordance with Eurocode 5 or a similar national Timber Code.

The design models allow the use of fasteners described in annex A to D.

No performance has been determined in relation to ductility of a joint under cyclic testing. The contribution to the performance of structures in seismic zones, therefore, has not been assessed.

See annex E to H for the joint's stiffness properties - to be used for the analysis of the serviceability limit state.

3.11 Aspects related to the performance of the product

Corrosion protection in service class 1, 2 and 3.

The use of IdeFix-connectors assembled with screws GoFix HK made of carbon steel according to ETA-11/0425 is limited to service class 1 and 2.

IdeFix-connectors and post-bases assembled with screws GoFix HK made of stainless steel according to

ETA-11/0425 and post-bases with ZaFix can additionally be used in service-class 3.

The connectors and post-bases with three layered coating are assessed to be equivalent at least to class C4 EN ISO 12944-2. Details of the corrosion protection system are deposited at ETA-Danmark.

3.12 General aspects related to the use of the product

IdeFix IF, IdeFix IFS and post-basis IdeFix STF, ZaFix STZ are manufactured in accordance with the provisions of this European Technical Approval using the manufacturing processes as identified in the inspection of the plant by the notified inspection body and laid down in the technical documentation.

The following provisions concerning product performance apply:

IdeFix If or IdeFix IFS Connector joints

A connector joint is deemed fit for its intended use provided:

- The header beam shall be restrained against rotation and be free from wane under the connector.

If the header carries joists only on one side the eccentricity moment from the joists

$$M_{ec} = R_{joist} (b_H/2)$$

shall be considered at the strength verification of the header.

R_{joist} Reaction force from the joists
 b_H Width of header

- For a header with joists from both sides but with different reaction forces a similar consideration applies.
- Connectors are fastened to wood-based members by bolts.
- The characteristic capacity of the connector joint is calculated according to the manufacturer's technical documentation, dated 2013
- The connector joint is designed in accordance with Eurocode 5 or an appropriate national code.
- There is no gap between the end of the joist and header, beam – column respectively.
- The height and depth of the joist or header shall be so large that the minimum fastener end and edge distances are observed.

Post-bases IdeFix STF or ZaFix STZ

- The characteristic capacity of the connector joint is calculated according to the manufacturer's technical documentation, dated 2013

- The connector joint is designed in accordance with Eurocode 5 or an appropriate national code.
- The post-bases is designed in accordance with Eurocode 3 or an appropriate national code.
- There is no gap between the end of the column and the column support plate of the post-base.
- The height and depth of the column shall be so large that the minimum fastener end and edge distances are observed.

The actual end bearing capacity of the timber member to be used in conjunction with the connector is checked by the designer of the structure to ensure it is not less than the connector capacity and, if necessary, the connector capacity reduced accordingly.

There are no specific requirements relating to preparation of the timber members.

4 Assessment and verification of constancy of performance (AVCP)

4.1 AVCP system

According to the decision 97/638/EC of the European Commission¹, as amended, the system(s) of assessment and verification of constancy of performance (see Annex V to Regulation (EU) No 305/2011) is 2+.

5 Technical details necessary for the implementation of the AVCP system, as foreseen in the applicable EAD

Technical details necessary for the implementation of the AVCP system are laid down in the control plan deposited at ETA-Danmark

Issued in Charlottenlund on 2014-06-26 by

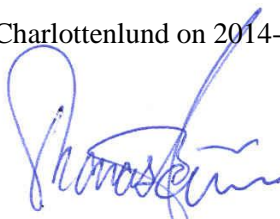

Thomas Bruun
Managing Director, ETA-Danmark

Annex A: IdeFix IF

1. Characteristic values of load-carrying-capacities and stiffness

1.1 Loading in tension of IdeFix IF

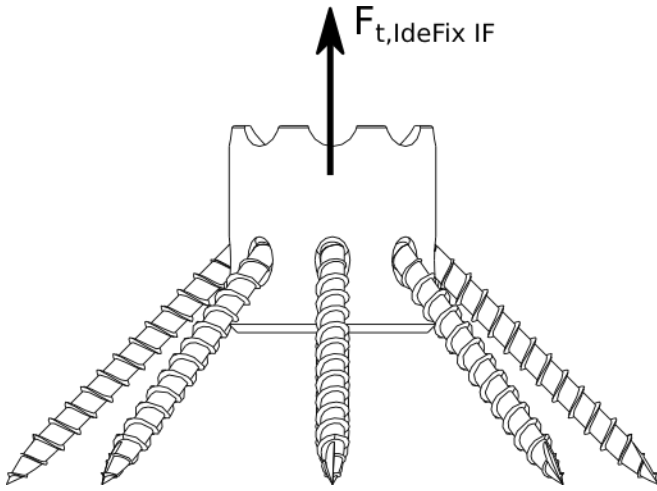

Figure 1: IdeFix IF in tension loading

Resistance:

$$F_{t,IdeFixIF,Rk} = n \cdot (F_{ax,\alpha,Rk} + F_{la,\alpha,Rk}) \cdot \cos(45^\circ)$$

with $F_{ax,\alpha,Rk}$, $F_{la,\alpha,Rk}$ for screws GoFix HK, properties and design according ETA-11/0425. Without taking in account the rod-effect for $F_{la,\alpha,Rk}$.

Stiffness:

$$\frac{n}{K_{IdeFix}} = \sqrt{\frac{1}{8} \cdot \left(\frac{1}{K_{ax}^2} + \frac{1}{K_{la}^2} \right)}$$

$$\text{with } K_{la} = \rho^{1,5} \cdot d/23; K_{ax} = 780 \cdot d^{0,2} \cdot l_{ef}^{0,4}$$

d: diameter of GoFix HK;

n: number of GoFix HK screws

Table 1: characteristic withdrawal resistance of IdeFix IF in timber of grade C24

IdeFix® IF Ø	GoFix HK made of carbon steel according to ETA-11/0425	$F_{t,IdeFix,Rk}$ [kN], C24	K_{ser} [kN/mm], C24
30 mm	d=5,0 mm, l_{ef} = 34 mm	17,00 kN	30,7 kN/mm
30 mm	d=5,0 mm, l_{ef} = 54 mm	25,60 kN	31,1 kN/mm
30 mm	d=5,0 mm, l_{ef} = 74 mm	32,40 kN	31,3 kN/mm
40 mm	d=6,0 mm, l_{ef} = 53 mm	29,00 kN	36,9 kN/mm
40 mm	d=6,0 mm, l_{ef} = 73 mm	37,90 kN	37,3 kN/mm
40 mm	d=6,0 mm, l_{ef} = 93 mm	45,60 kN	37,5 kN/mm
50 mm	d=8,0 mm, l_{ef} = 81 mm	56,00 kN	48,9 kN/mm

1.2 Loading of IdeFix IF by shearing force

Three different failure modes have to be verified.

Mode a) embedding of IdeFix IF in end-grain of joist or column

The resistance of IdeFix IF is calculated as proposed in EC 5 for ring-connector joints,

$$V_{90} = \frac{k_h}{k_{90}} \cdot \min \left\{ k_1 \cdot k_2 \cdot k_3 \cdot k_4 \cdot 35 \cdot d_c^{1,5} \right. \\ \left. k_1 \cdot k_3 \cdot h_e \cdot 31,5 \cdot d_c \right\} \text{ with } d_c: \text{IdeFix diameter, } h_e \text{ depth of embedment and}$$

$$k_1 = k_2 = k_4 = 1, k_h = 0,65.$$

load-carrying capacity of self-tapping screws GoFix HK

$n=5$ screws are supposed to contribute ($n=10$ for IdeFix IF 500 with two rows of screws).

The screws' load carrying capacity is calculated according to EC5 clause 8.2.3, equation (8.10) and ETA-11/0425.

$$F_{modea, IdeFixIF, Rk} = V_{90} + F_{V, Rk, ETA-11/0425}$$

Mode b)

$$F_{modeb, IdeFixIF, Rk} = f_{h, 90, bolt} \cdot d_{bolt} \cdot \left(\sqrt{e_{bolt}^2 + \frac{2 \cdot M_y}{d_{bolt} \cdot f_{h, 90, bolt}}} - e_{bolt} \right) + F_{ax, screws} / 4.$$

Rod effect is taken into account as $F_{ax, screws} / 4$ with $n=5$ screws ($n=10$ for IdeFix IF 500 with two rows of screws) contributing and the screws' load carrying capacity according to ETA-11/0425.

Table 2: embedding depth h_e ; distance e_{bolt}

diameter IdeFix IF	embedding depth h_e in joist or column	e_{bolt}
30 mm	20 mm	10 mm
40 mm	25 mm	15 mm
50 mm	30 mm	20 mm

Mode c) tension perpendicular to grain for the joist or column according to EC 5

$$F_{modec, IdeFixIF, Rk} = 14 \cdot b_{joist} \cdot \sqrt{\frac{h_e}{(1-h_e/h_{joist})}}$$

The shearing force capacity of IdeFix IF in end-grain is the minimum value of these three modes.

Slip modulus for IdeFix IF connections in end-grain: $K_{ser} = 1,2 \cdot \rho_m^{1,5} \cdot d_c / 2$

Table 3: characteristic shearing force capacity of IdeFix IF in timber grade C24

IdeFix® IF Ø	GoFix HK made of carbon steel according to ETA-11/0425	$b_{NT} = h_{NT}$	$F_{V90, IdeFix, Rk}, C24$	$K_{ser}, C24$
30 mm	d=5,0 mm, l_{ef} = 34 mm	100 mm	10,1 kN (mode a)	7,56 kN/mm
30 mm	d=5,0 mm, l_{ef} = 54 mm	120 mm	12,3 kN (mode b)	7,56 kN/mm
30 mm	d=5,0 mm, l_{ef} = 74 mm	140 mm	13,8 kN (mode b)	7,56 kN/mm
40 mm	d=6,0 mm, l_{ef} = 53 mm	120 mm	13,0 kN (mode c)	10,1 kN/mm
40 mm	d=6,0 mm, l_{ef} = 73 mm	160 mm	18,8 kN (mode b)	10,1 kN/mm
40 mm	d=6,0 mm, l_{ef} = 93 mm	180 mm	20,5 kN (mode b)	10,1 kN/mm
50 mm	d=8,0 mm, l_{ef} = 81 mm	160 mm	20,5 kN (mode c)	12,6 kN/mm

1.3 Combined loading of IdeFix IF by shearing force and tension force

Clause 8.3.3, equ. (8.28) of EN 1995-1-1:2010 is applied:
$$\left(\frac{F_{ax,Ed}}{F_{t,IdeFixIF,Rd}}\right)^2 + \left(\frac{F_{V,Ed}}{F_{V,IdeFixIF,Rd}}\right)^2 \leq 1,0$$

1.4 Multiple IdeFix IF connectors per joint

For joints with more than one IdeFix IF connector the bearing capacity of the joint is found by multiplying the capacity for one IdeFix IF with the number of connectors n_{IdeFix} .

For joints loaded by shearing force mode c of Annexe A1.2 as a verification of tension perpendicular to grain shall not be multiplied by n_{IdeFix} .

Verification for wood members according to Eurocode 5 have to be done consciously.

2. IdeFix IF, product details, definitions and installation

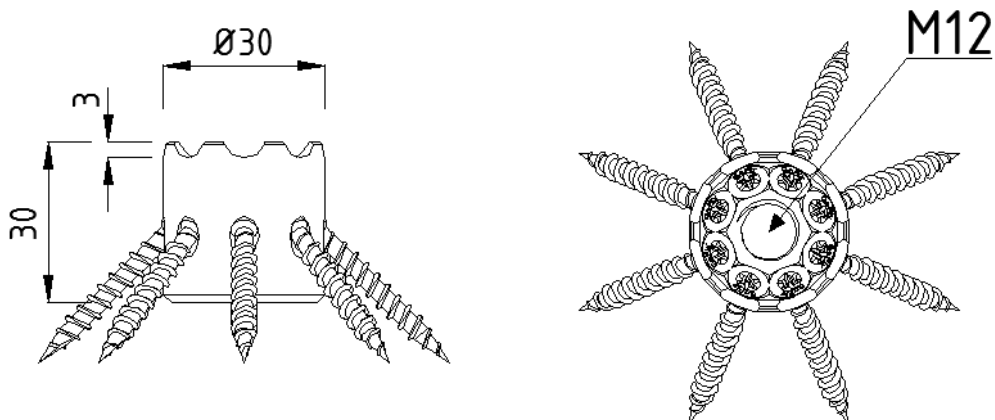

Figure 2: IdeFix IF series 300

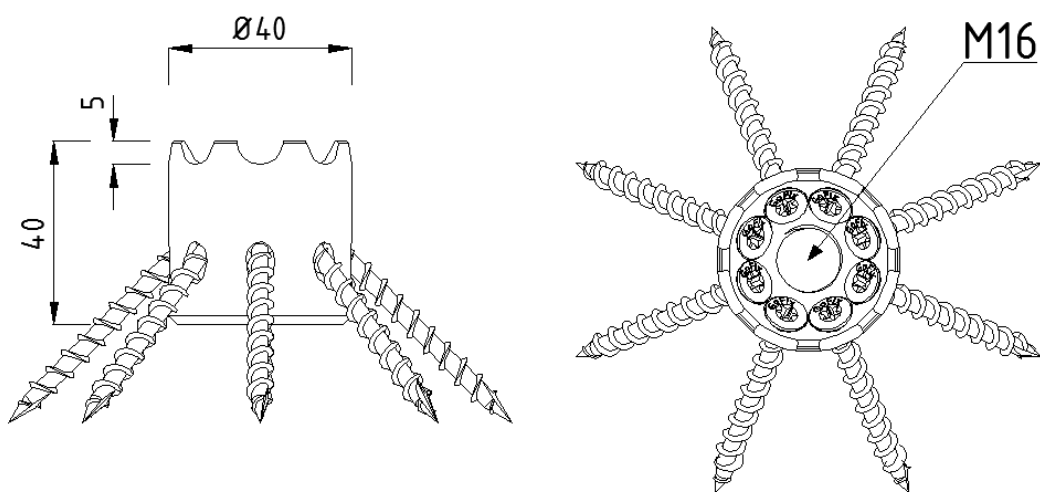

Figure 3: IdeFix IF series 400

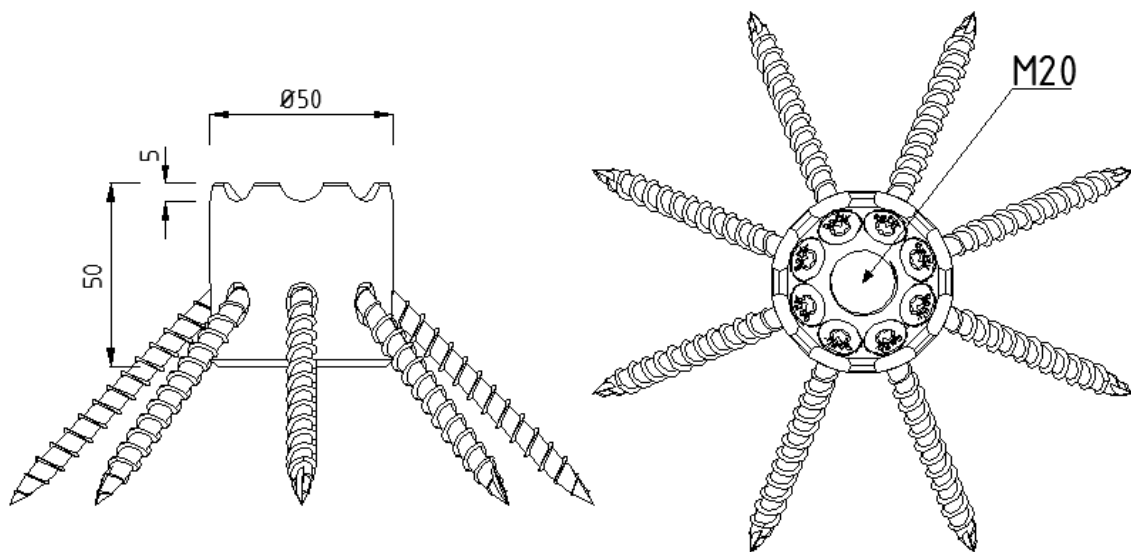
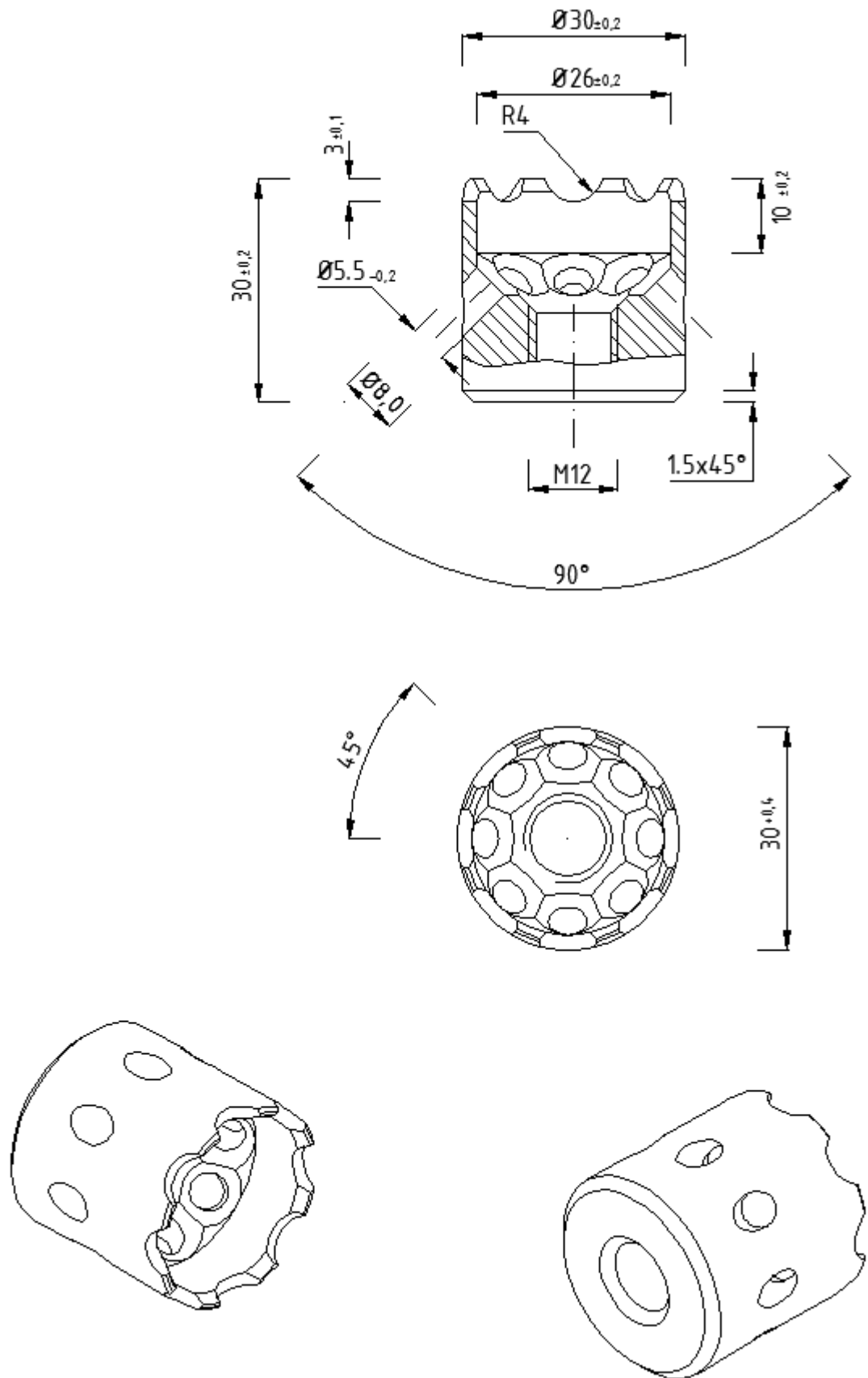

Figure 4: IdeFix IF series 500

Cylindrical part made of steel 1.0715 according to EN 10087 and self-tapping screws GoFix HK with properties assessed in ETA-11/0425

2.1 IdeFix IF series 300, details:



2.2 IdeFix IF series 400, details:

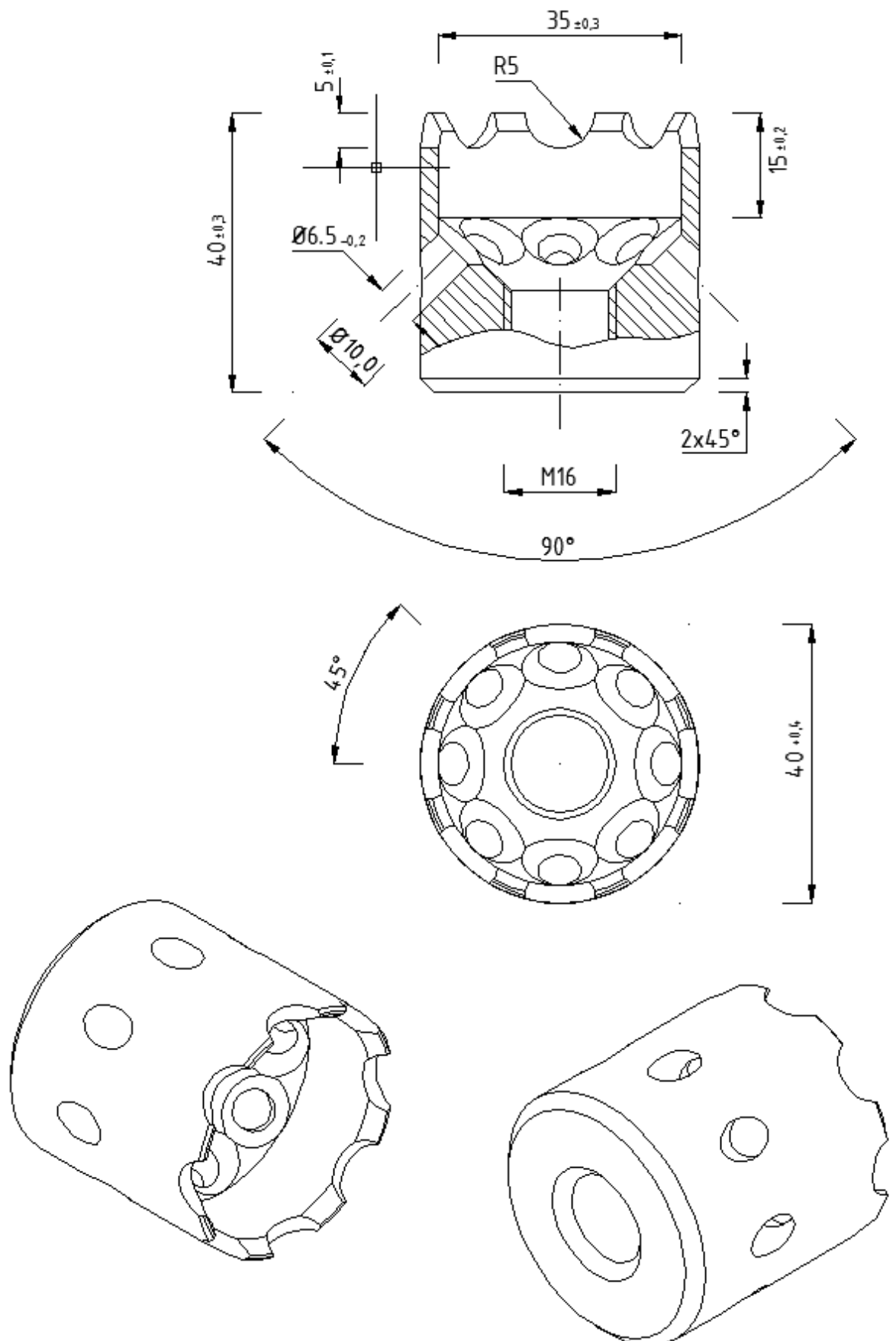

2.3 IdeFix IF series 500, details:

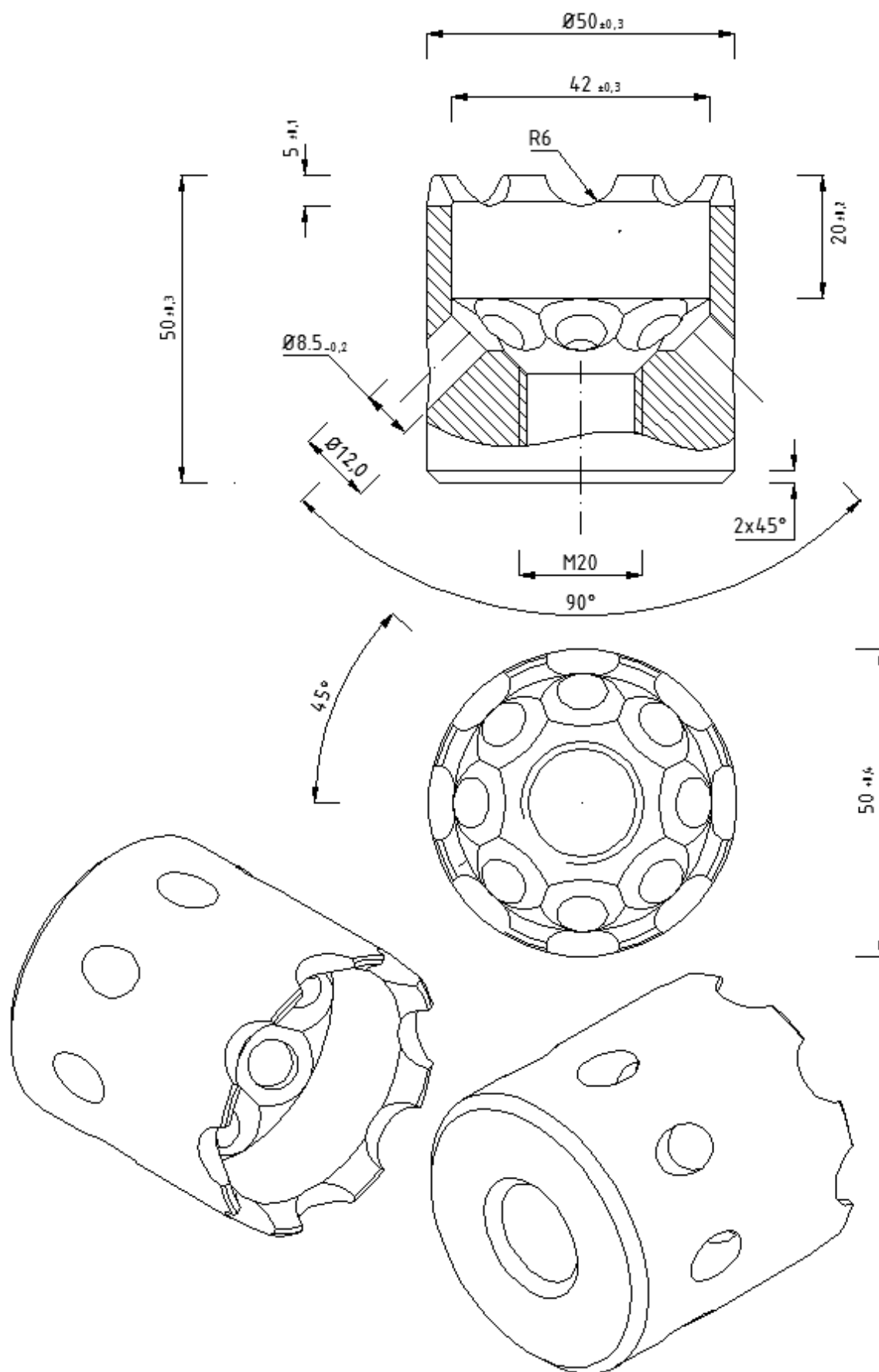

2.4 IdeFix IF series 500 with two rows of screws, details:

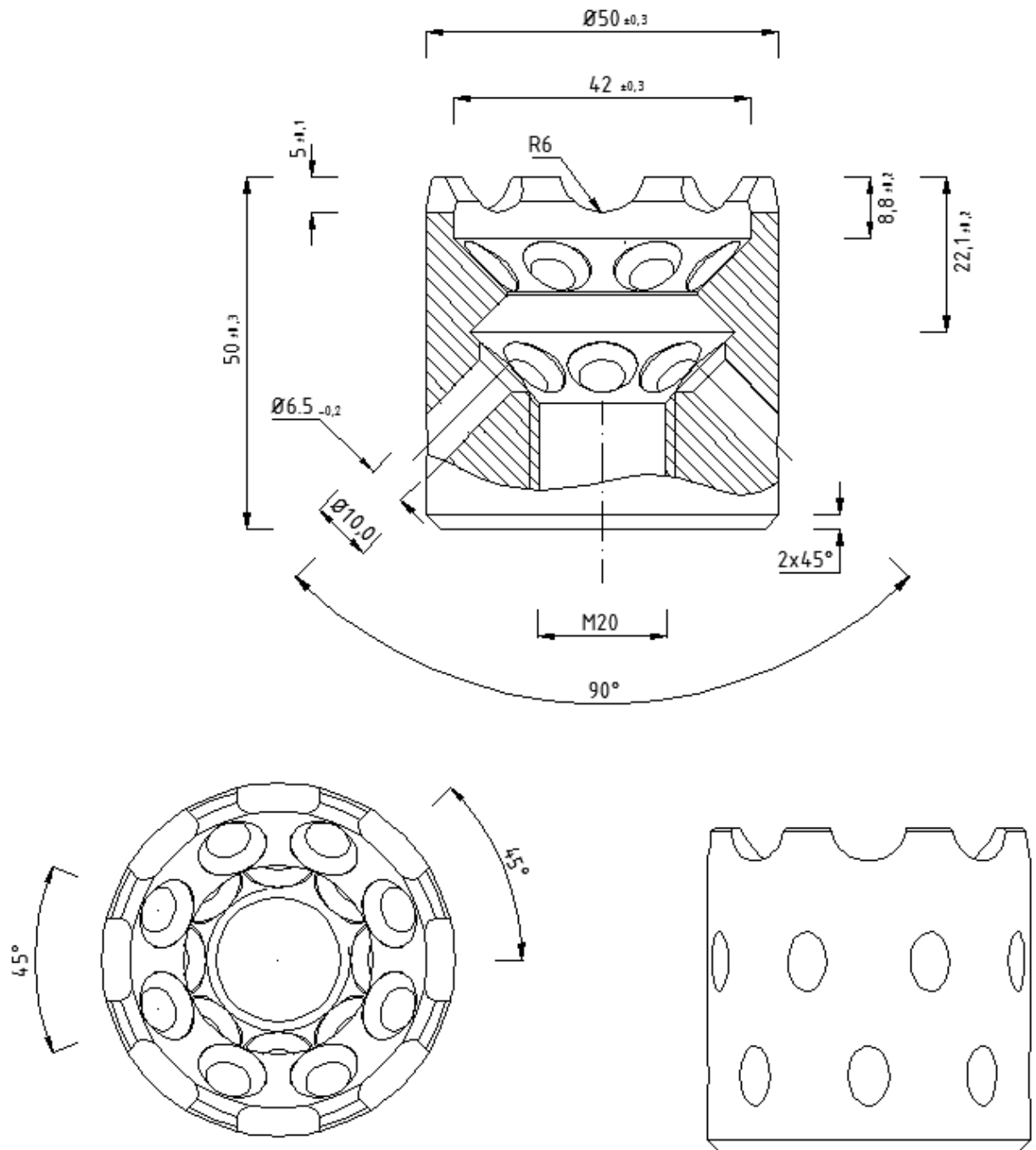

2.5 IdeFix IF screws, GoFix HK, ETA -11 / 0425, geometry:

GoFix HK 5,0

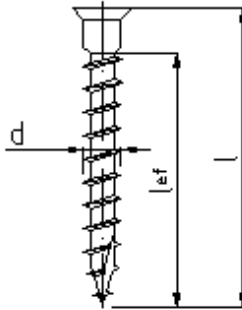

GoFix HK 6,0

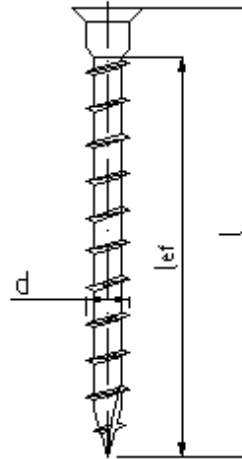

GoFix HK 8,0

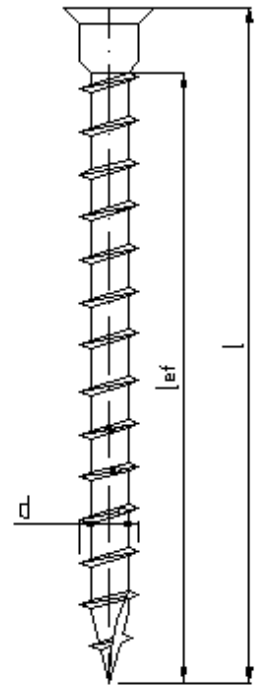

Figure 5: IdeFix IF screws

Table 4: IdeFix IF screws, details

IdeFix		GoFix HK		
IF	\varnothing	d	l	lef
304	30	5,0	40	34
306	30	5,0	60	54
308	30	5,0	80	74
406	40	6,0	60	53
408	40	6,0	80	73
410	40	6,0	100	93
509	50	8,0	90	81

2.6 IdeFix IF installation:

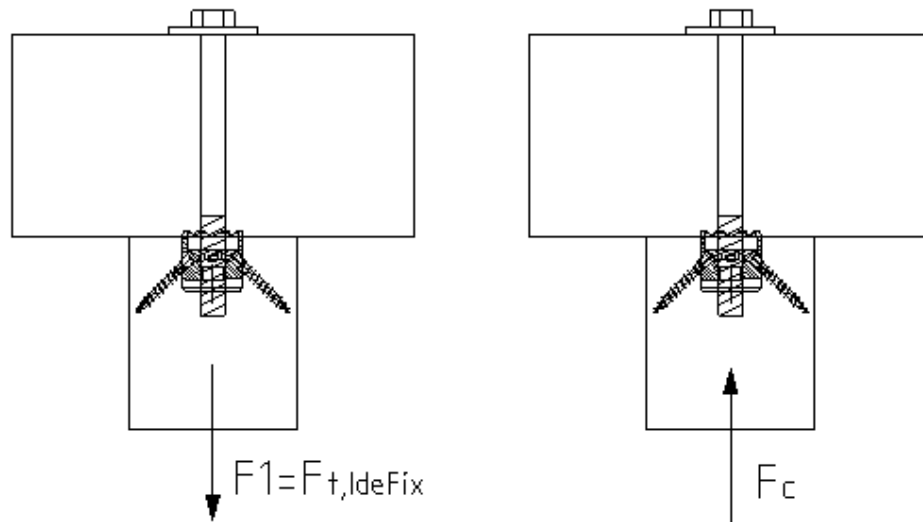

Figure 6: Tension connection with anti-twist protection, bolted joint connection

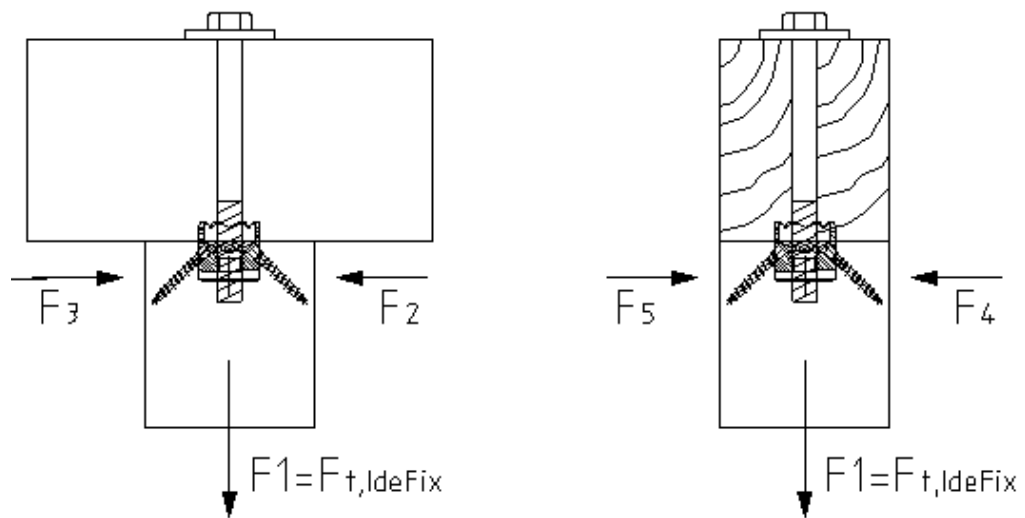

Figure 7: Column to main beam connection with anti-twist protection, bolted joint connection

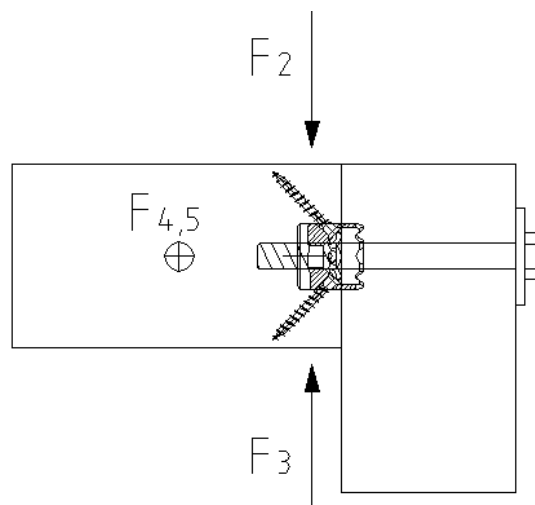

Figure 8: Header- joist connection with anti-twist protection, bolted joint connection

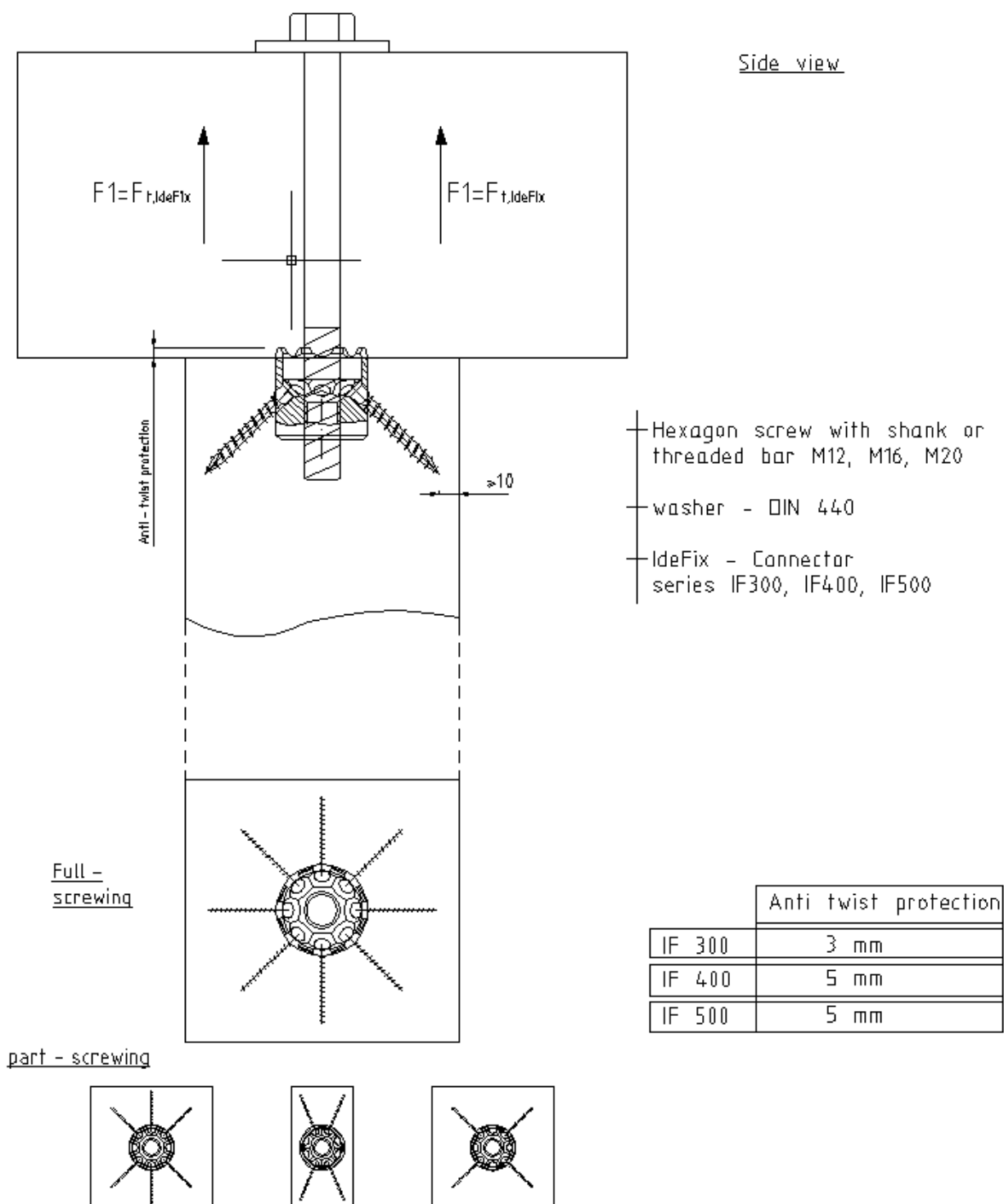

Figure 9: Tension Connection, details

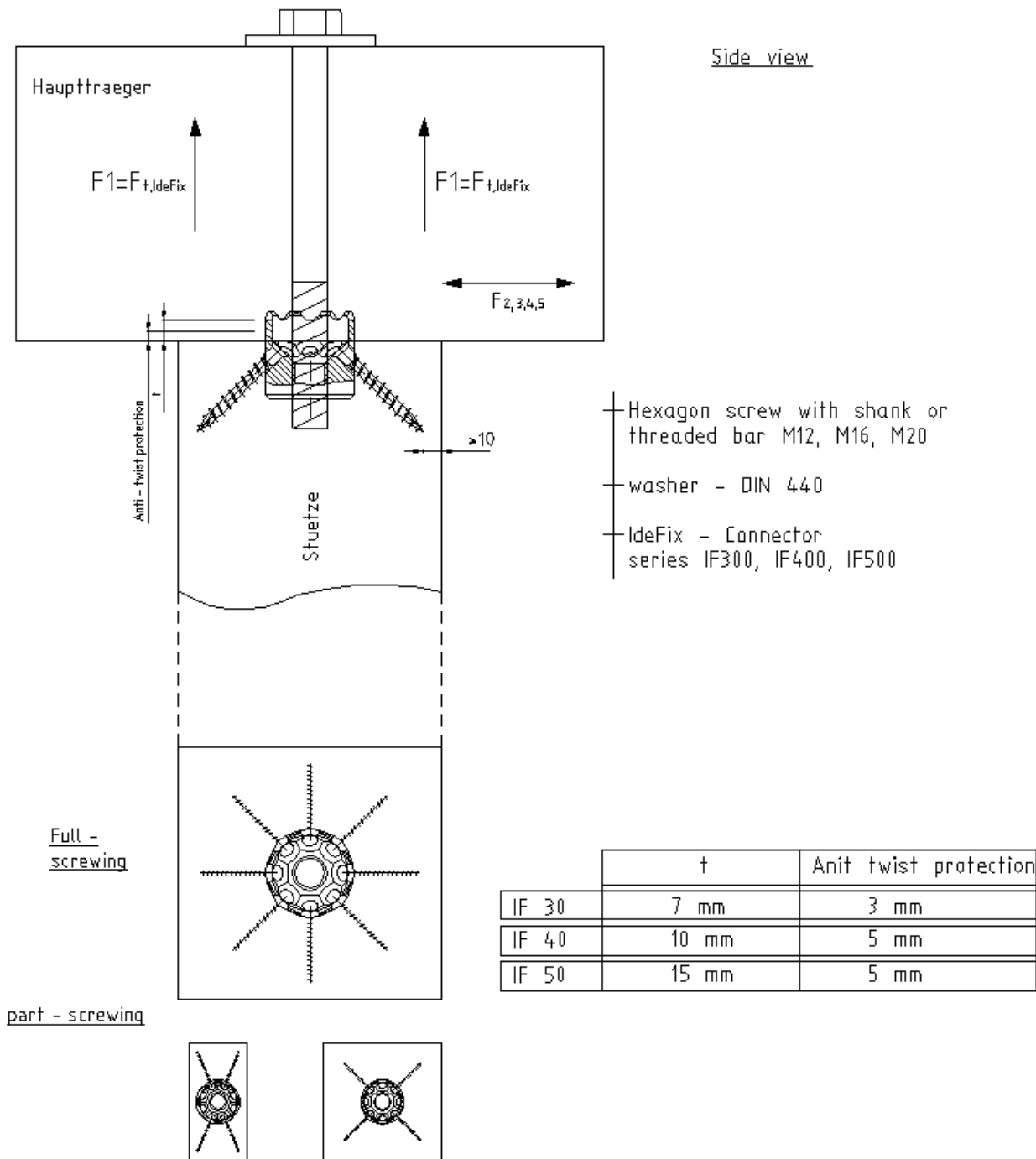

Figure 10: Bolted Joint Connection, details

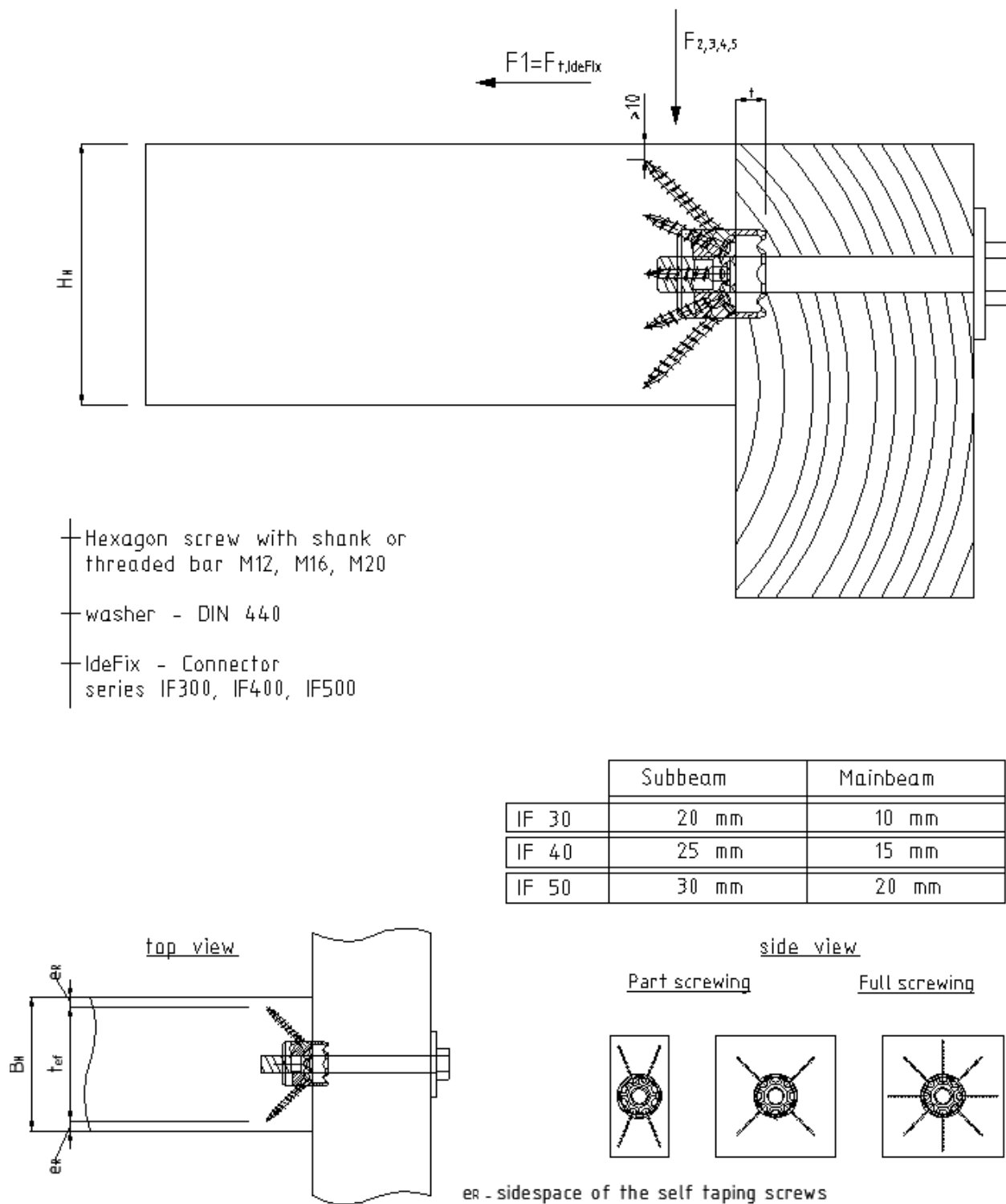

Figure 11: Secondary beam to Mainbeam connection, details

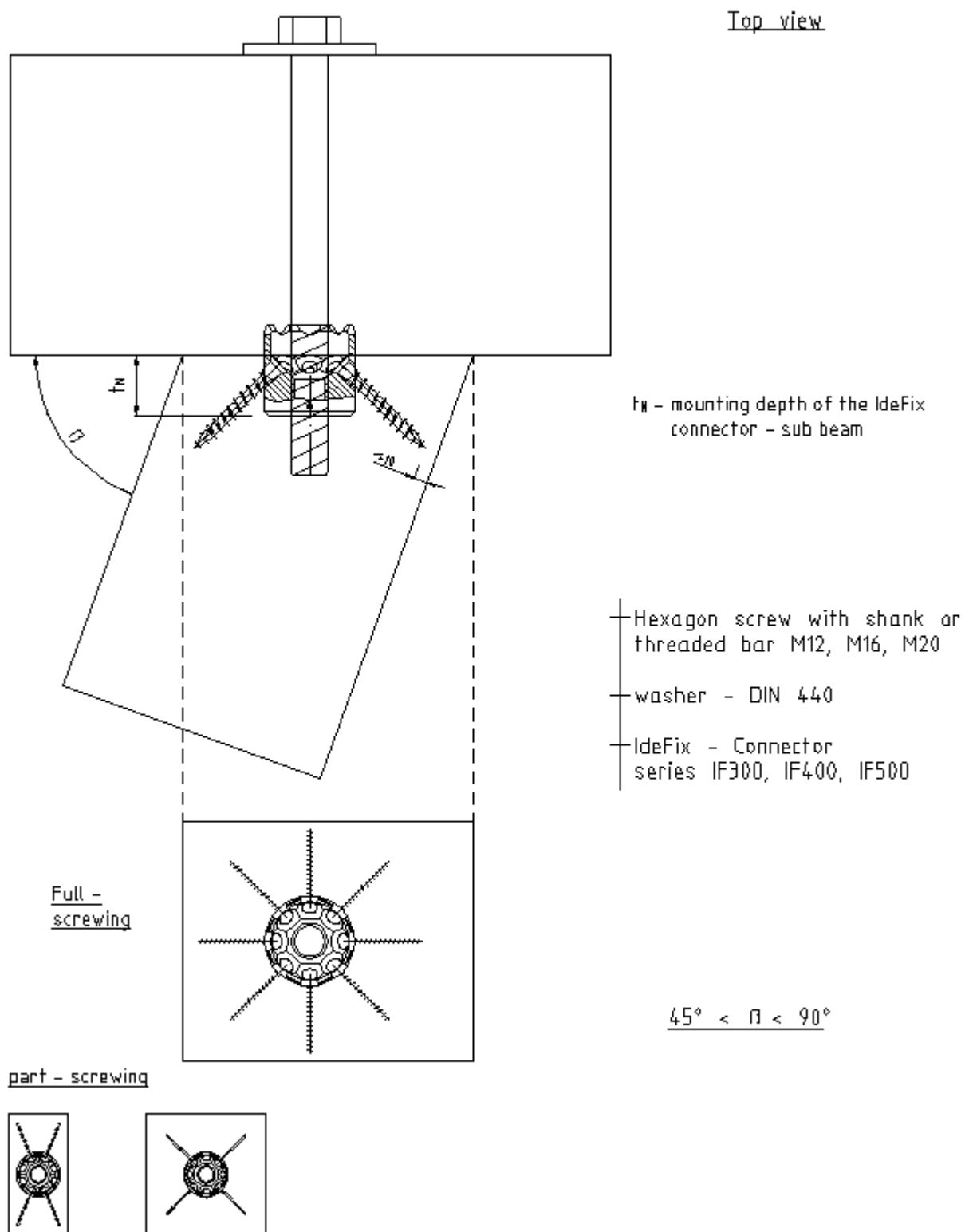
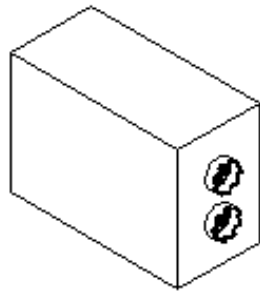
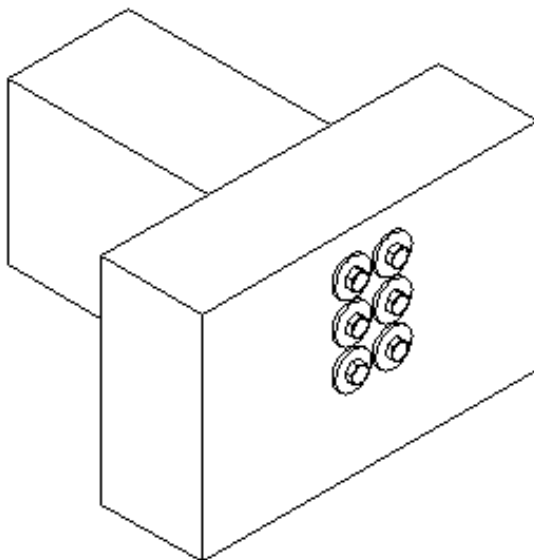
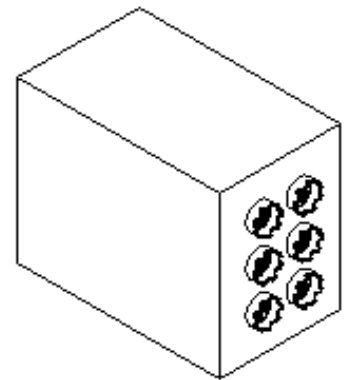

Figure 12: Subbeam to Mainbeam connection - angle, details



Main- Subbeam
multiple port
single row

Main- Subbeam
multiple port
double multi row



Main- Subbeam
multiple port
finished connection

Figure 13: Multiple port connection

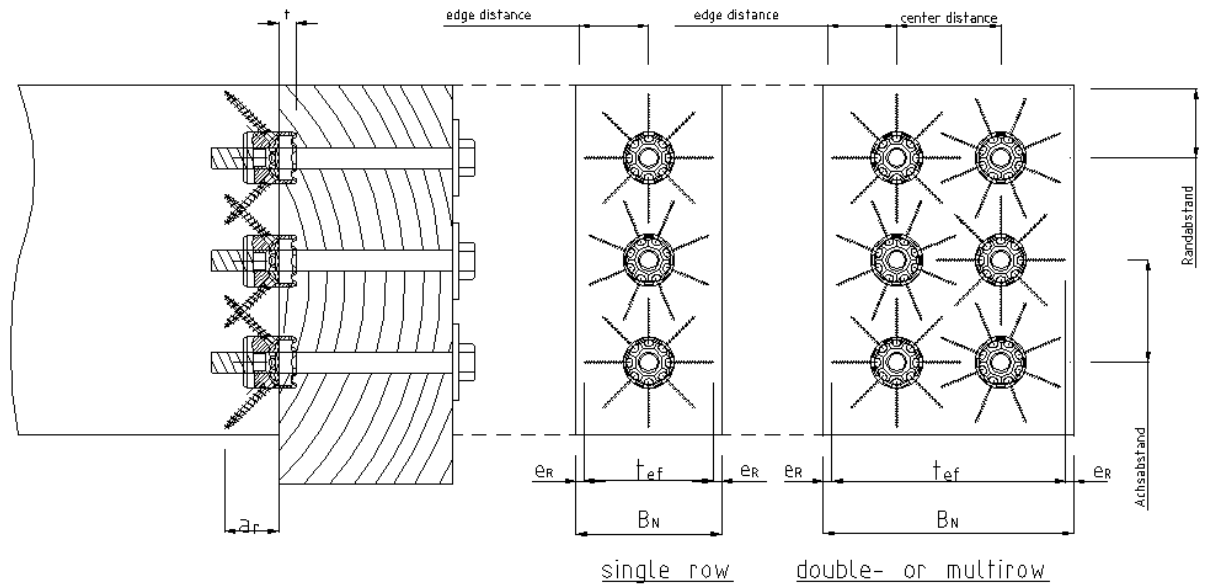

	sub beam	main beam
IF 300	20 mm	10 mm
IF 400	25 mm	15 mm
IF 500	30 mm	20 mm

	edge distance	center distance
IF 300	50 mm	50 mm
IF 400	60 mm	60 mm
IF 500	80 mm	80 mm

Figure 14: Multiple port connection, details

Annex B: IdeFix IFS

1. IdeFix IFS product details, definitions and installation

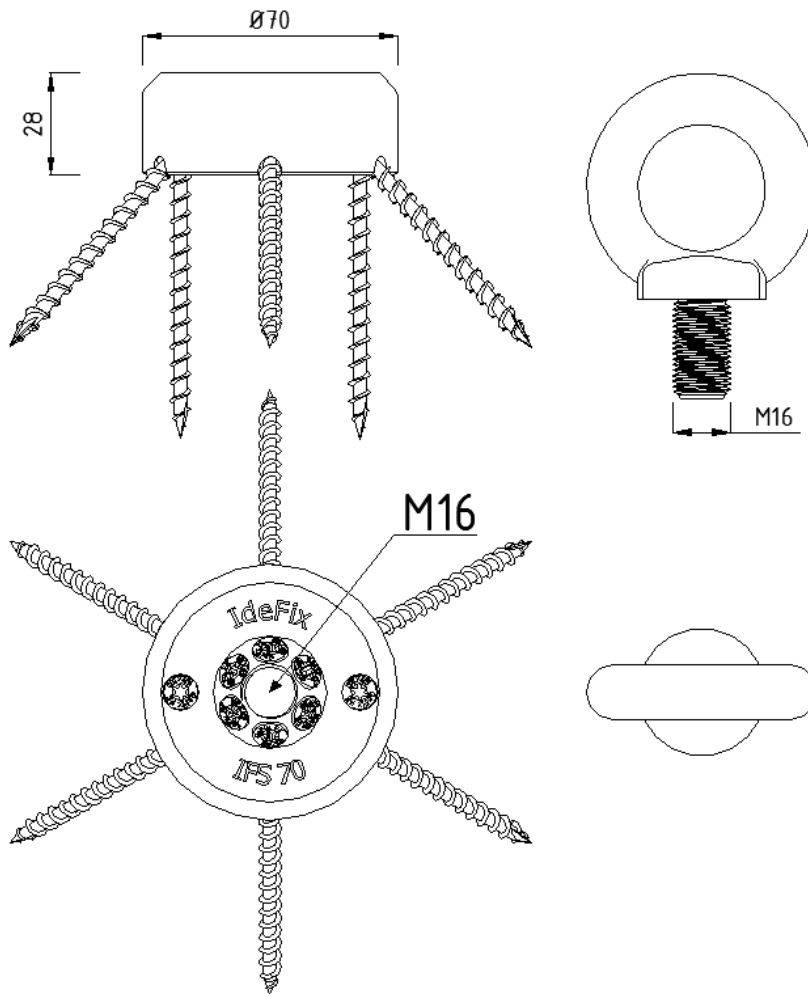

Figure 15: IdeFix IFS

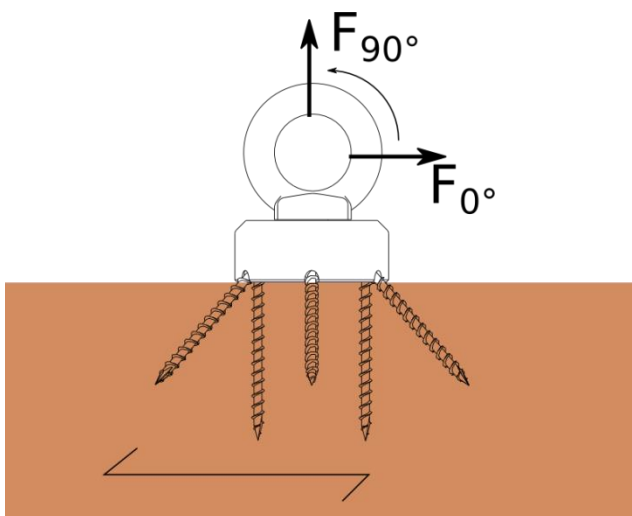

Figure 16: IdeFix IFS loading

Table 5: IdeFix IFS geometry, screws

IdeFix® IFS Ø	GoFix HK ETA-11/0425
70 mm	d=6,0 x 100 mm, l_{ef} = 63 mm for screws with an angle of 45°
70 mm	d=6,0 x 100 mm, l_{ef} = 72 mm for screws with an angle of 90°

Properties of the eye bolt are not assessed within this ETA, verification has to be done according to Eurocode 3. This connector is not applied in the end-grain.

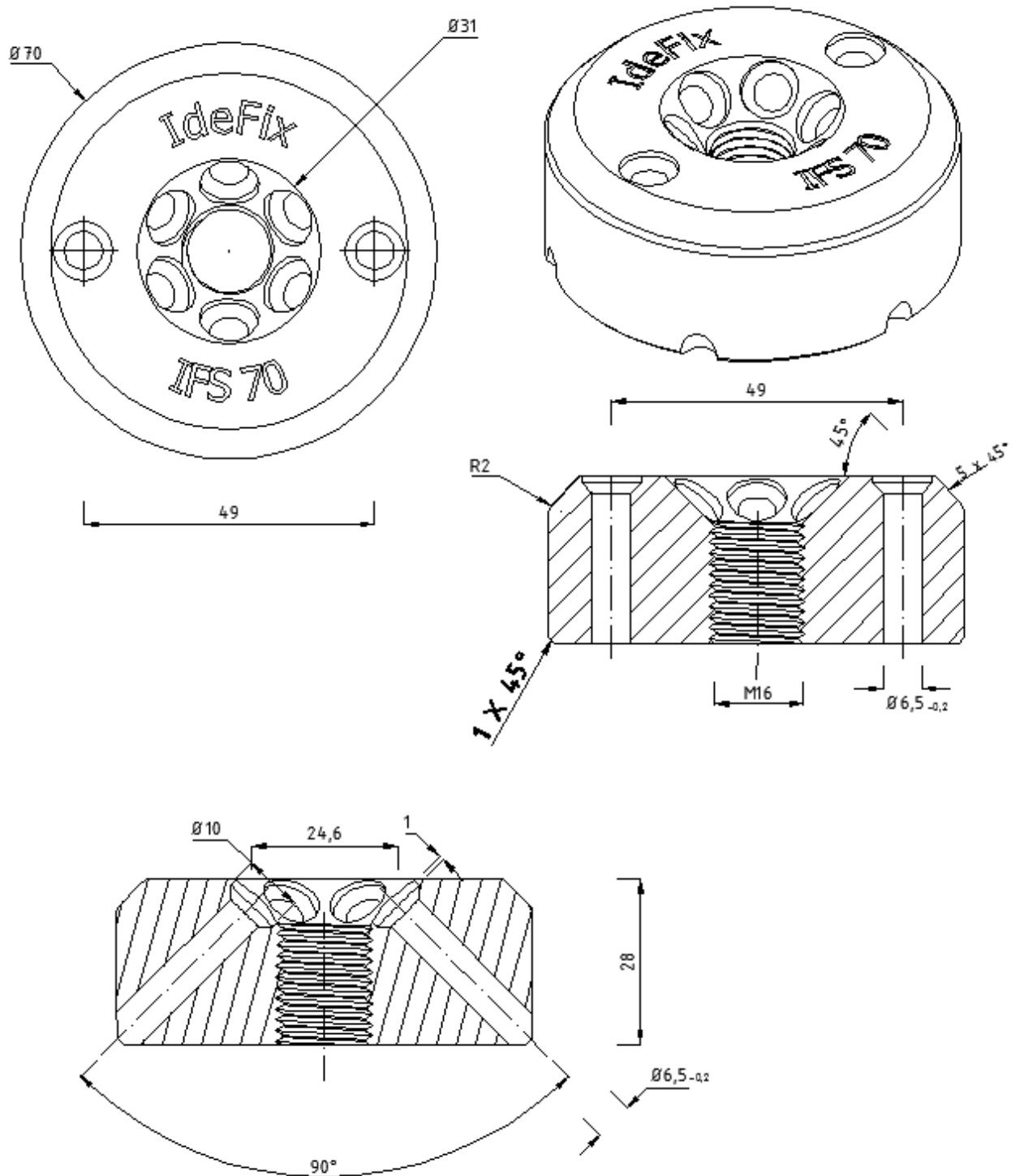

Figure 17: IdeFix IFS, details

2. IdeFix IFS Characteristic values of load-carrying-capacities and stiffness

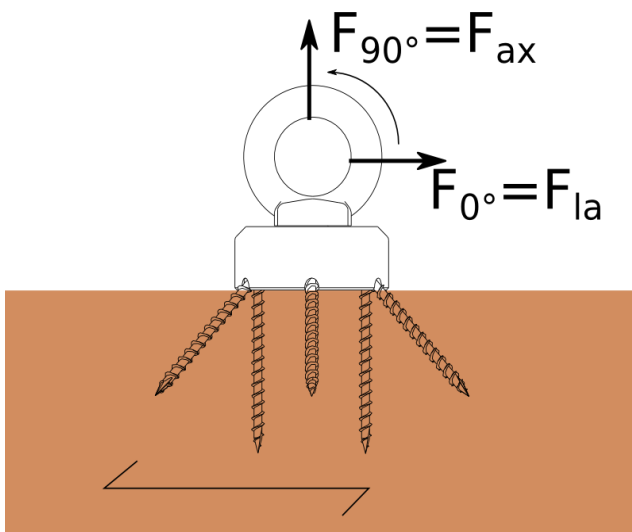

Figure 18: IdeFix IFS loading

Axial withdrawal resistance

$$F_{ax,IdeFixIFS} = 6 \cdot (F_{45^\circ,ax,Rk} + F_{45^\circ,la,Rk}) \cdot \cos(45^\circ)$$

with $F_{45^\circ,ax,Rk}$, $F_{45^\circ,la,Rk}$ for screws GoFix HK, properties and design according ETA-11/0425. Without taking in account the rod-effect for $F_{la,\alpha,Rk}$.

Load-carrying capacity for shearing forces

$$F_{la,IdeFixIFS} = 2 \cdot (F_{45^\circ,ax} + F_{45^\circ,la}) \cdot \cos(45^\circ)$$

Combined loading

$$\left(\frac{F_{ax,Ed}}{F_{ax,IdeFixIFS,Rd}} \right)^2 + \left(\frac{F_{V,Ed}}{F_{V,IdeFixIFS,Rd}} \right)^2 \leq 1,0$$

Characteristic values for IdeFix IFS made of carbon steel according to ETA-11/0425 and timber grade C24

$$F_{ax,IdeFixIFS,k} = F_{ax,Rk} = 25,5 \text{ kN}$$

$$F_{la,IdeFixIFS,k} = F_{v,Rk} = 8,5 \text{ kN}$$

$$F_{45^\circ,Rk} = 11,4 \text{ kN}$$

Annex C: ZaFix ZF

1. Characteristic values of load-carrying-capacities and stiffness

1.1 Loading in tension of ZaFix ZF

$$F_{ZaFix,\emptyset 30mm,ax,Rk} = \frac{\rho_k}{350kg/m^3} \cdot 5,70 \text{ kN}; \quad F_{ZaFix,\emptyset 40mm,ax,Rk} = \frac{\rho_k}{350kg/m^3} \cdot 5,70 \text{ kN}$$

$$F_{ZaFix,\emptyset 30mm,C24} = 5,70 \text{ kN}; \quad F_{ZaFix,\emptyset 40mm,C24} = 5,70 \text{ kN}$$

$$K_{ser,ZaFix,\emptyset 30mm} = \frac{\rho_k}{350kg/m^3} \cdot 23,0 \text{ kN/mm}; \quad K_{ser,ZaFix,\emptyset 40mm} = \frac{\rho_k}{350kg/m^3} \cdot 23,0 \text{ kN/mm}$$

1.2 Loading of ZaFix ZF by shearing force

Two different failure modes are taken into account:

mode a)

$$\text{Embedding in column of ZaFix cylinder } F_{modea,ZaFix,V,Rk} = 0,65 \cdot 0,84 \cdot f_{h,EC5,dowel}/2 \cdot l_{ZaFix} \cdot d_{ZaFix}$$

$$\text{with } f_{h,EC5,dowel} = 0,082 \cdot (1 - 0,01 \cdot d_{ZaFix}) \cdot \rho$$

mode b) tension perpendicular to grain for the column according to EC 5

$$F_{modeb,ZaFix,V,Rk} = 14 \cdot b_{column} \cdot \sqrt{\frac{h_e}{(1-h_e/h_{column})}}$$

Table 6: embedding depth of ZaFix l_{ZaFix}

\emptyset ZaFix ZF	embedding in column
30 mm	70 mm
40 mm	90 mm

$$\text{Slip modulus: } K_{ser} = 2/3 \cdot 1/2 \cdot \rho_m^{1,5} \cdot d_{ZaFix}/23$$

Table 7: characteristic value of shear capacity C24

	$F_{V,k,modela}$	K_{ser}
ZaFix $\emptyset 30$ mm	11,5 kN	3,74 kN/mm
ZaFix $\emptyset 40$ mm	16,9 kN	5,0 kN/mm

1.3 Combined loading of ZaFix ZF by shearing force and tension force

Clause 8.3.3, equ. (8.27) of EN 1995-1-1:2010 is applied: $\frac{F_{ax,Ed}}{F_{ZaFix,t,Rd}} + \frac{F_{V,Ed}}{F_{ZaFix,V,Rd}} \leq 1,0$

2. ZaFix ZF product details, definitions and installation

ZaFix connector is used only as assembled kit with post base.

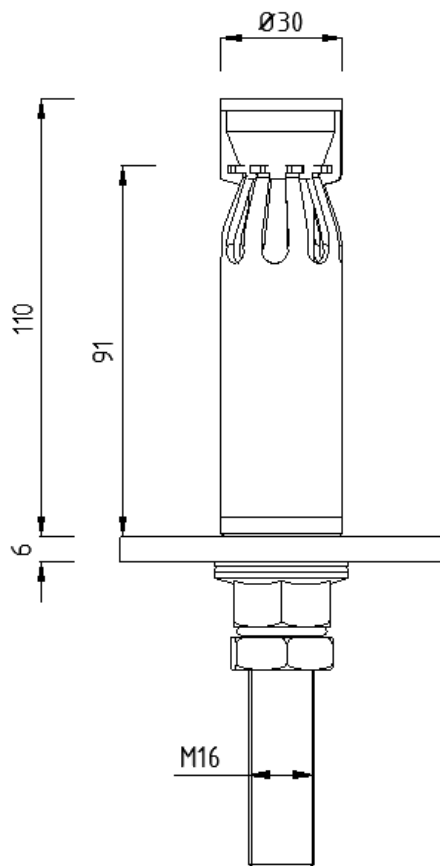

Figure 19: ZaFix ZF d=30

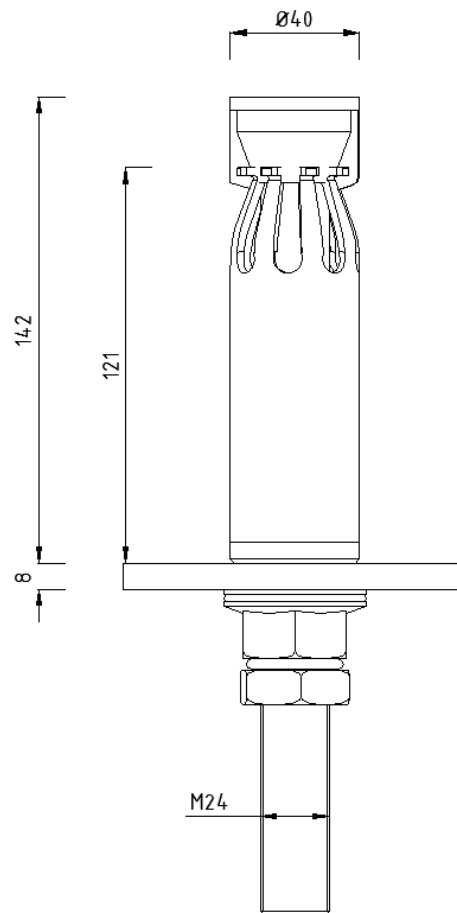
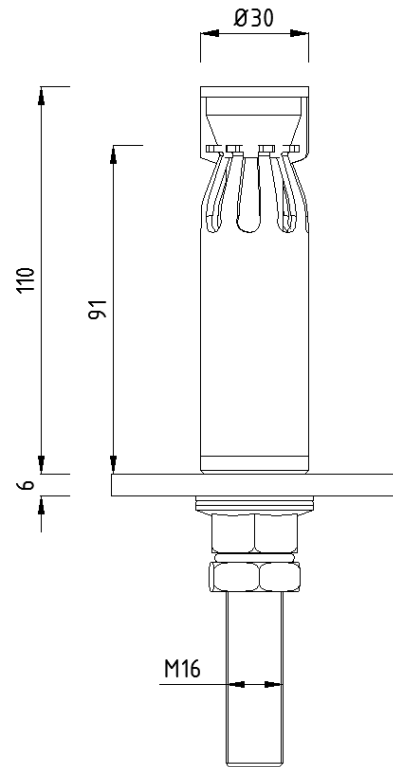

Figure 20: ZaFix ZF d=40

Threaded rod made of 1.0401, EN 10277 (C15); the cone to force the profiled tube outward is formed of this rod. The tube is made from 1.0308, EN 10216, EN 10305 (E235) with $t=2,5$ mm for ZaFix Ø30mm or $t=2,0$ mm for ZaFix Ø40mm.



- threaded rod with expand conus M16
- Tube Ø 30 mm (wall thickness 2,5) E235
- Washer Ø80 x 6 S235JR
- Shouldered nut M16 with O-ring DIN 6923 / FK 8
- O-ring
- Counter nut M16 DIN 439 / FK4

Figure 21: ZaFix ZF d=30, details

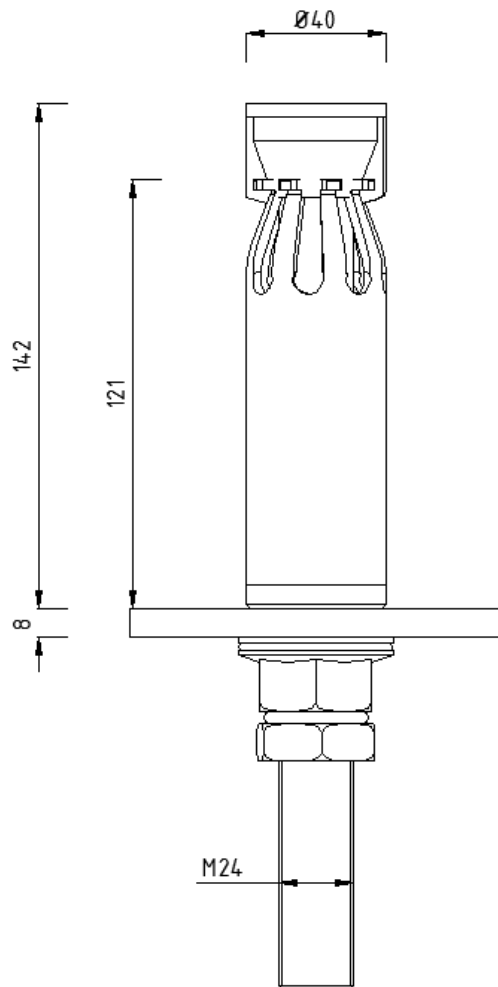

- threaded rod with expand conus M24
- Tube Ø 40 mm (wall thickness 2,0) E235
- Washer Ø95 x 8 S235JR
- Shouldered nut M24 with O-ring DIN 6923 / FK 8
- O-ring
- Counter nut M24 DIN 439 / FK4

Figure 22: ZaFix ZF d=40, details

Annex D: Post-bases

1. Characteristic values of load-carrying-capacities and stiffness

For post-bases loaded in tension or by horizontal shearing forces the connector IdeFix IF or ZaFix have to be verified according to Annex A or Annex C respectively.

1.1 Post-bases loaded in tension

IdeFix IF's or ZaFix's withdrawal capacity according to Annex A 1.1 or Annex C 1.1 is to be verified.

1.2 Loading of post-bases by horizontal forces (shearing force)

The verification of the post-base subjected to bending has to be done according to EN 1993-1-1 and EN 1993-1-8. For the bending resistance of the threaded rod and the connection of rod to lower tube the characteristic resistance for bending according to Table 8 is used with $\gamma_{M2} = 1,25$.

Table 8: characteristic values threaded rod

STF	$M_{k,rod}$
STF 300 series	163 kNmm
STF 400 series	318 kNmm
STF 700 series	549 kNmm

1.3 Post-bases loaded in compression

First failure mode for the post base under compression load is yielding of rod

mode a) $F_{c,k,modea} \leq 0,9 \cdot f_{ub} \cdot A_s = F_{t,Rd}$ with $\gamma_{M2} = 1,25$

Second failure mode for the post base under compression load is yielding of the tube

mode b) $F_{c,k,modeb} \leq f_y \cdot A_{tube}$ with $\gamma_{M0} = 1,0$

Third failure mode is buckling of rod, with buckling length according to Figure 23.

If the column's foot is horizontally fixed, the buckling length might be reduced according to buckling scheme. For threaded rods of higher property class as 4.6 a simplifying approach of taking the complete length of the post base as buckling length for the rod or a more exact calculation according to Eurocode 3 of columns with different cross section is applied for all series.

mode c) $F_{c,k,postbase} = \chi \cdot A \cdot f_y$ with $\gamma_{M1} = 1,1$ mode c) is only to be applied if $\bar{\lambda} > 0,2$

mode d finally takes account of timber's compressive strength.

mode d) IdeFix: $F_{c,k} = f_{c,0} \cdot \pi/4 \cdot d_a^2$
 ZaFix: $F_{c,k} = f_{c,0} \cdot \pi/4 \cdot (d_a^2 - d_{ZaFix}^2)$

γ_M for stresses parallel to grain according to EC5

Verification is done with $F_{post-base,c,Rd} = \min\{F_{c,d,modea}; F_{c,d,modeb}; F_{c,d,modec}; F_{c,d,moded}; \}$

$$\frac{N_{Ed}}{F_{post-base,c,Rd}} \leq 1$$

1.4 Combined loading of post-bases by horizontal force and tension force

The verification has to done for IdeFix IF or ZaFix according annex to A 1.3. or annex C 1.3

1.5 Combined loading of post-bases by horizontal force and compression force

$$\frac{N_{Ed}}{F_{post-base,c,Rd}} + \frac{M_{Ed}}{M_{c,Rd}} \leq 1 \text{ with } F_{post-base,c,Rd} \text{ according to annex D 1.3 and } M_{c,Rd} \text{ according to 1.2}$$

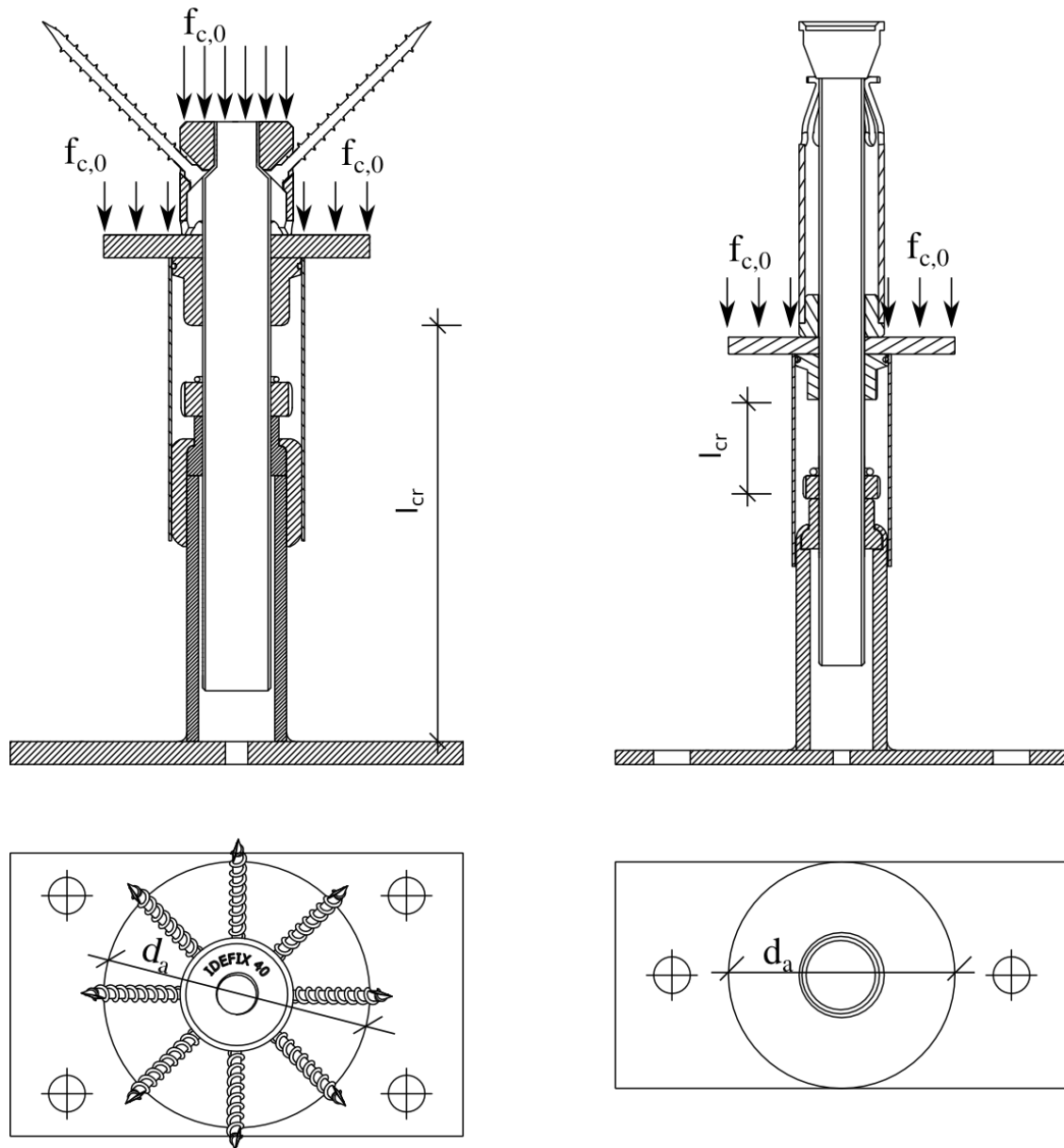

Figure 23: post bases IdeFix STF and ZaFix STZ 300, 400,700, buckling length and compressive stresses

2. Post bases product details, definitions and installation

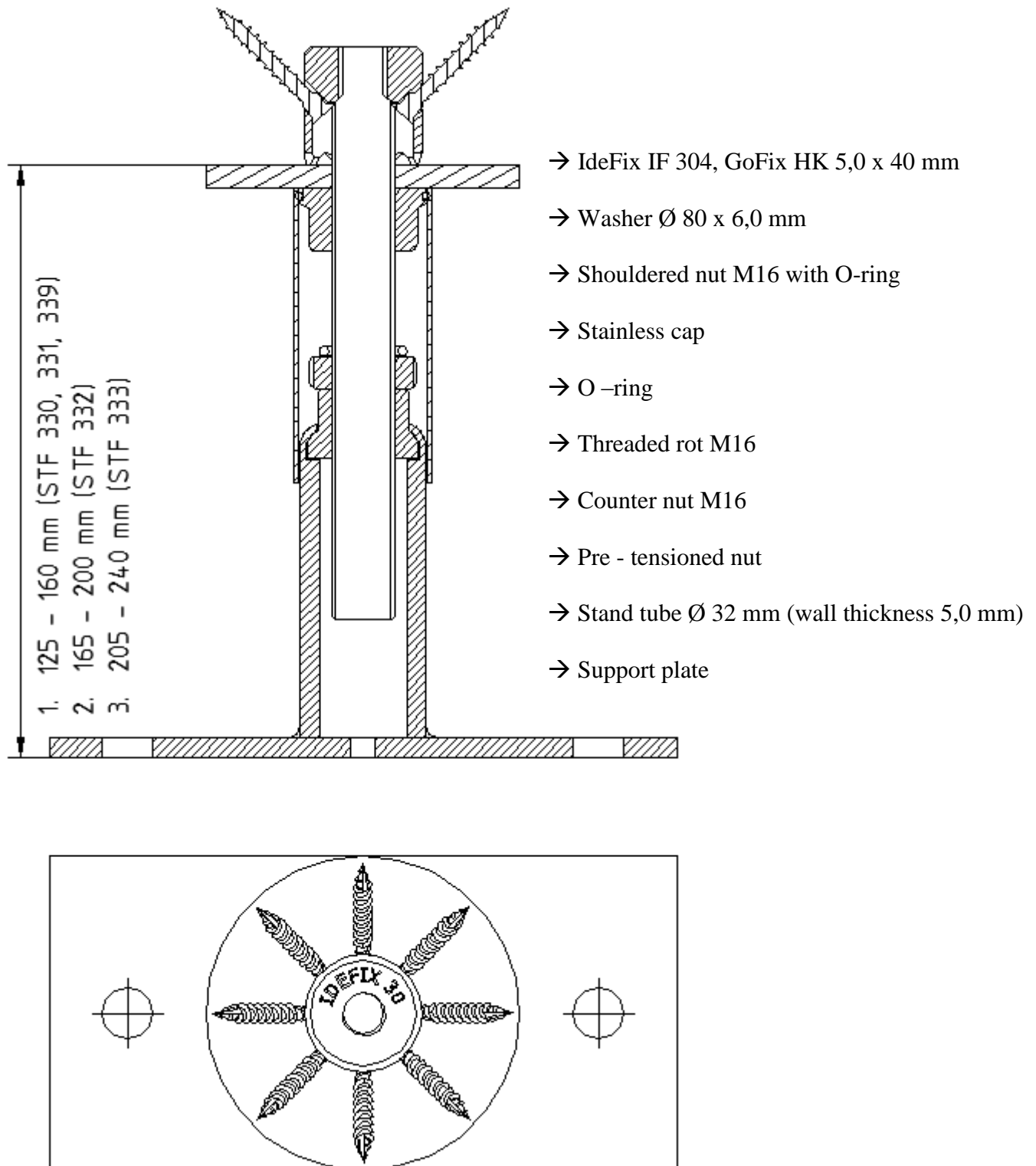

Figure 24: STF / STZ 300 series with IdeFix IF or ZaFix ZF

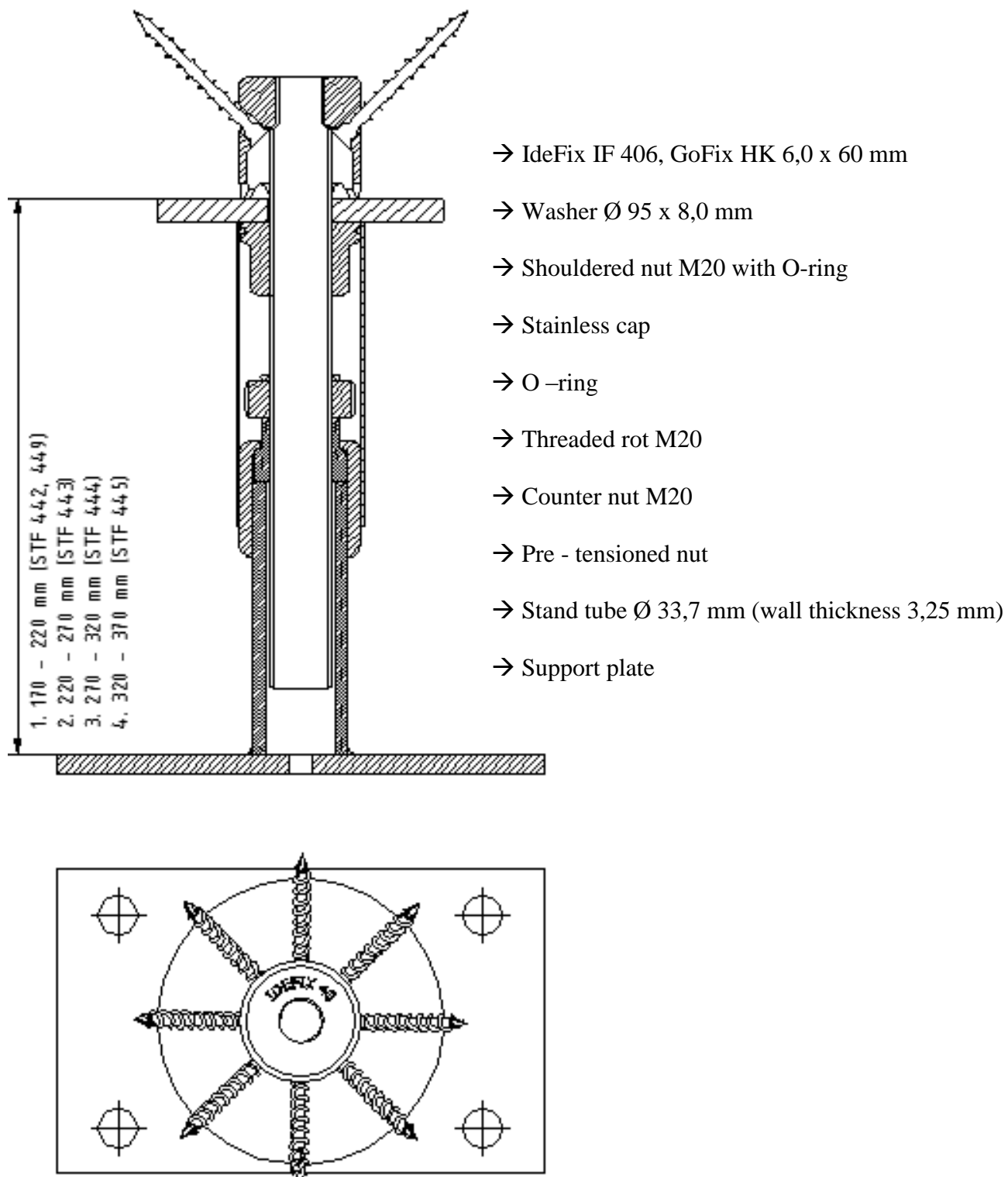

Figure 25: STF / STZ 400 series with IdeFix IF or ZaFix ZF

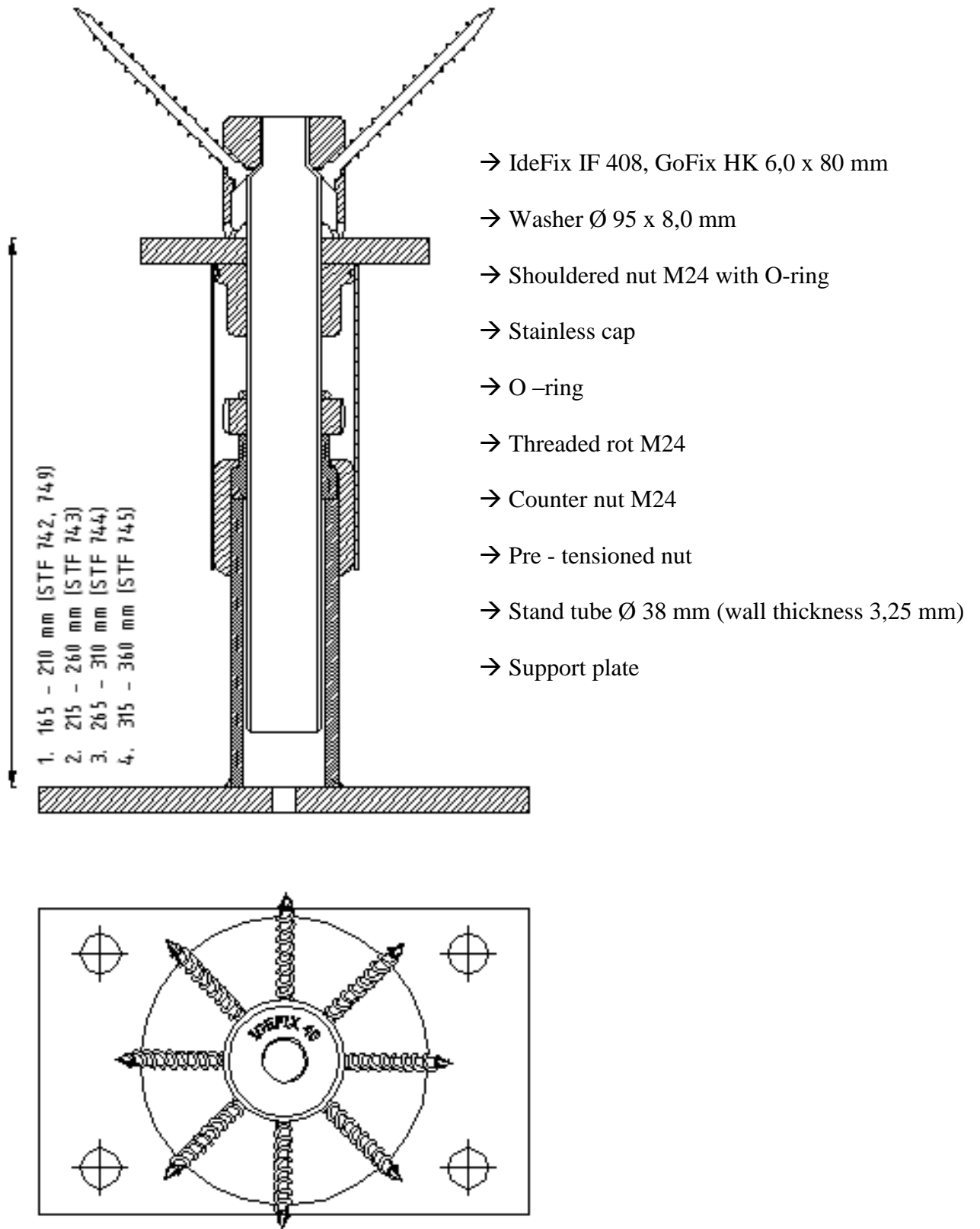

Figure 26: STF / STZ 700 series with IdeFix IF or ZaFix ZF

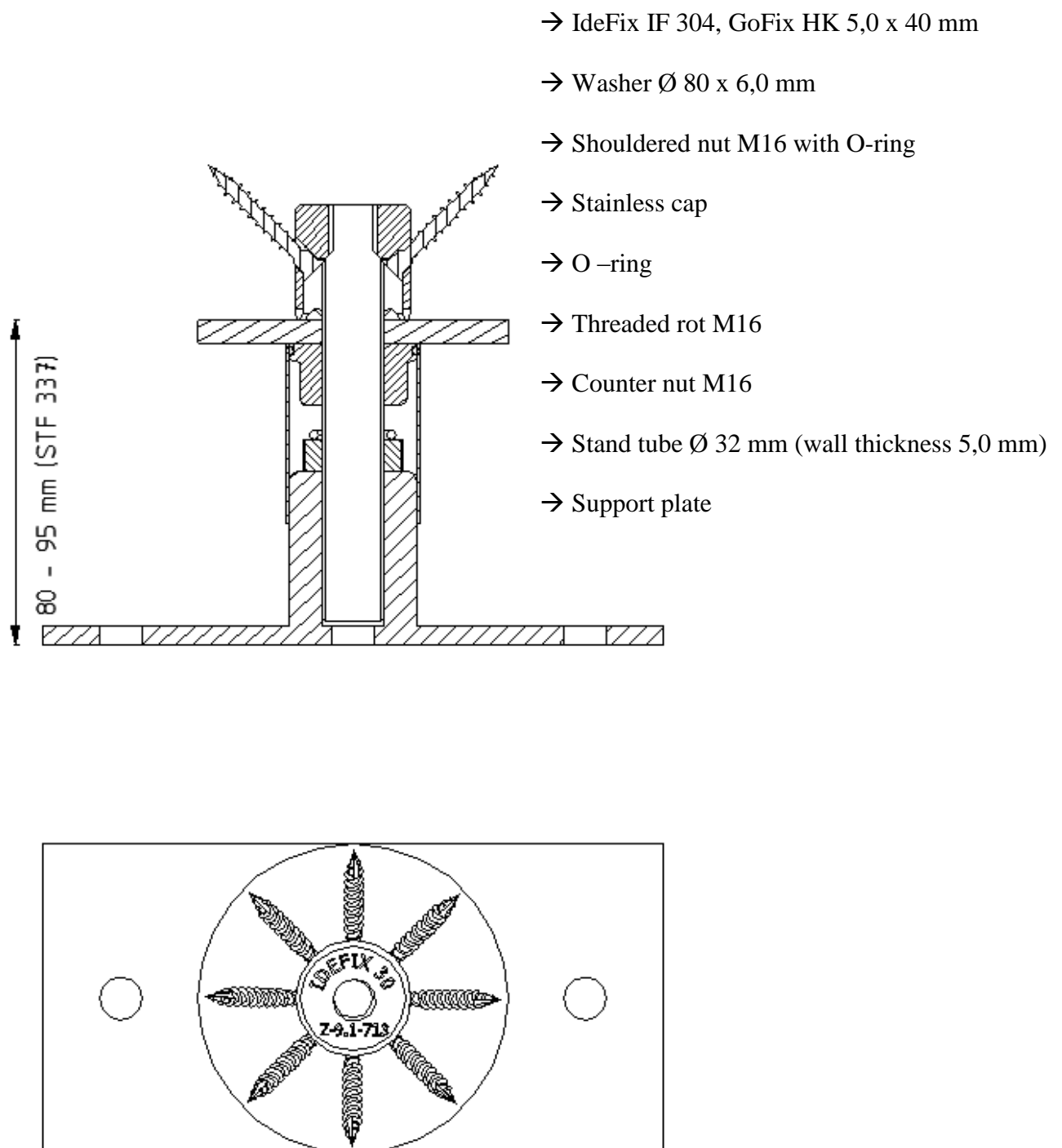

Figure 27: STF 337 with IdeFix IF

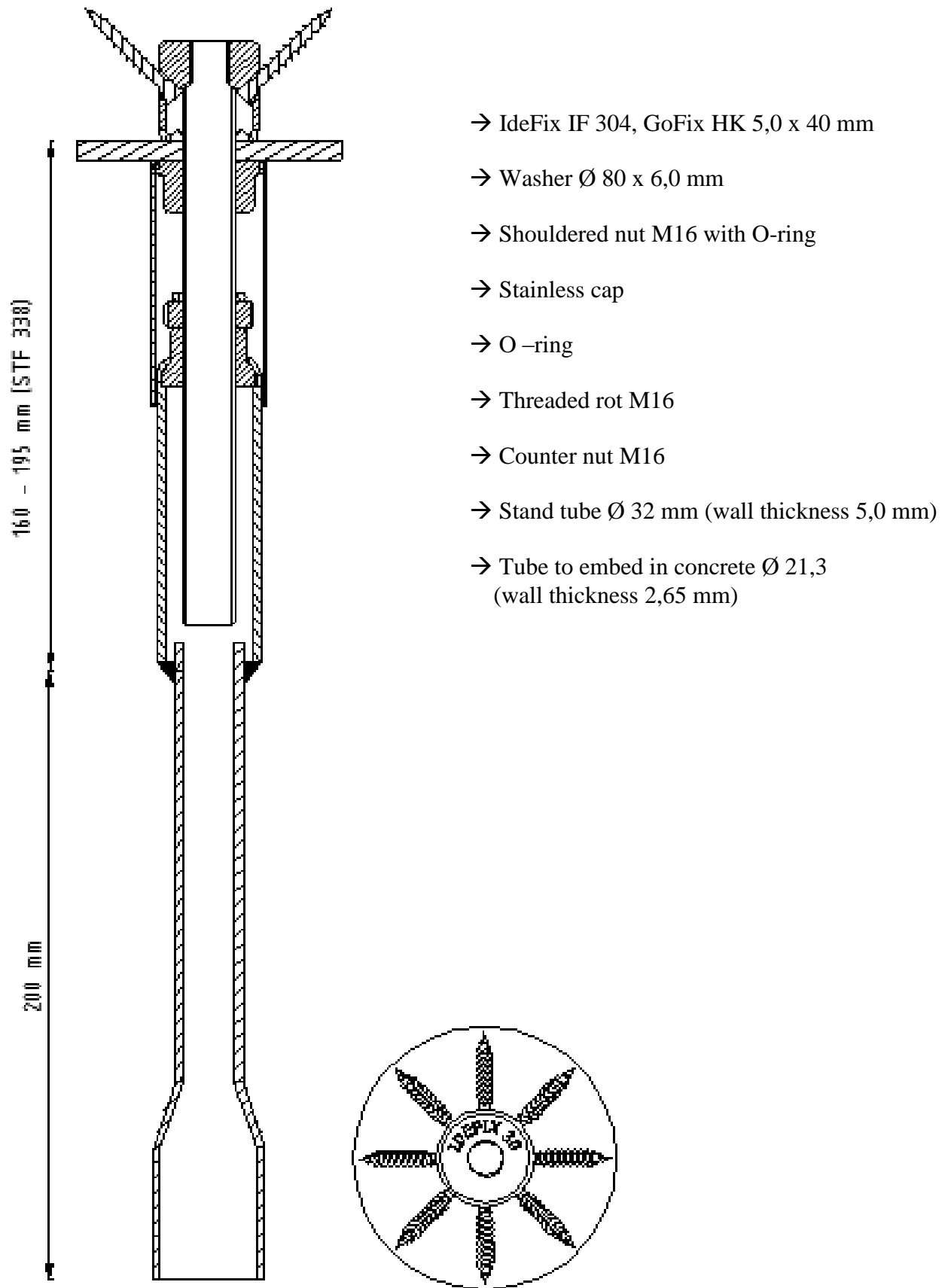

Figure 28: STF /STZ 338 with IdeFix IF or ZaFix ZF

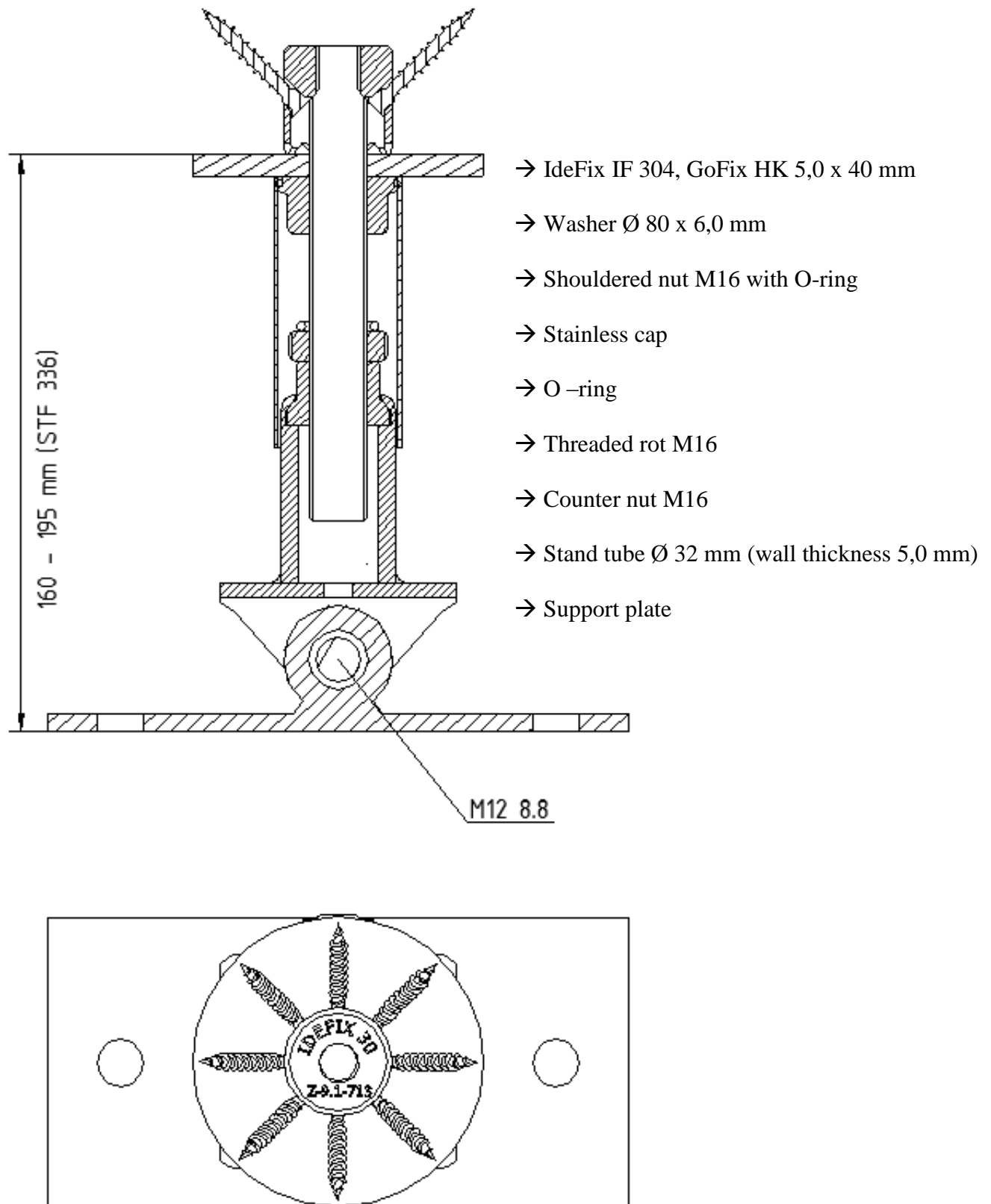

Figure 29: STF /STZ 336 with IdeFix IF or ZaFix ZF

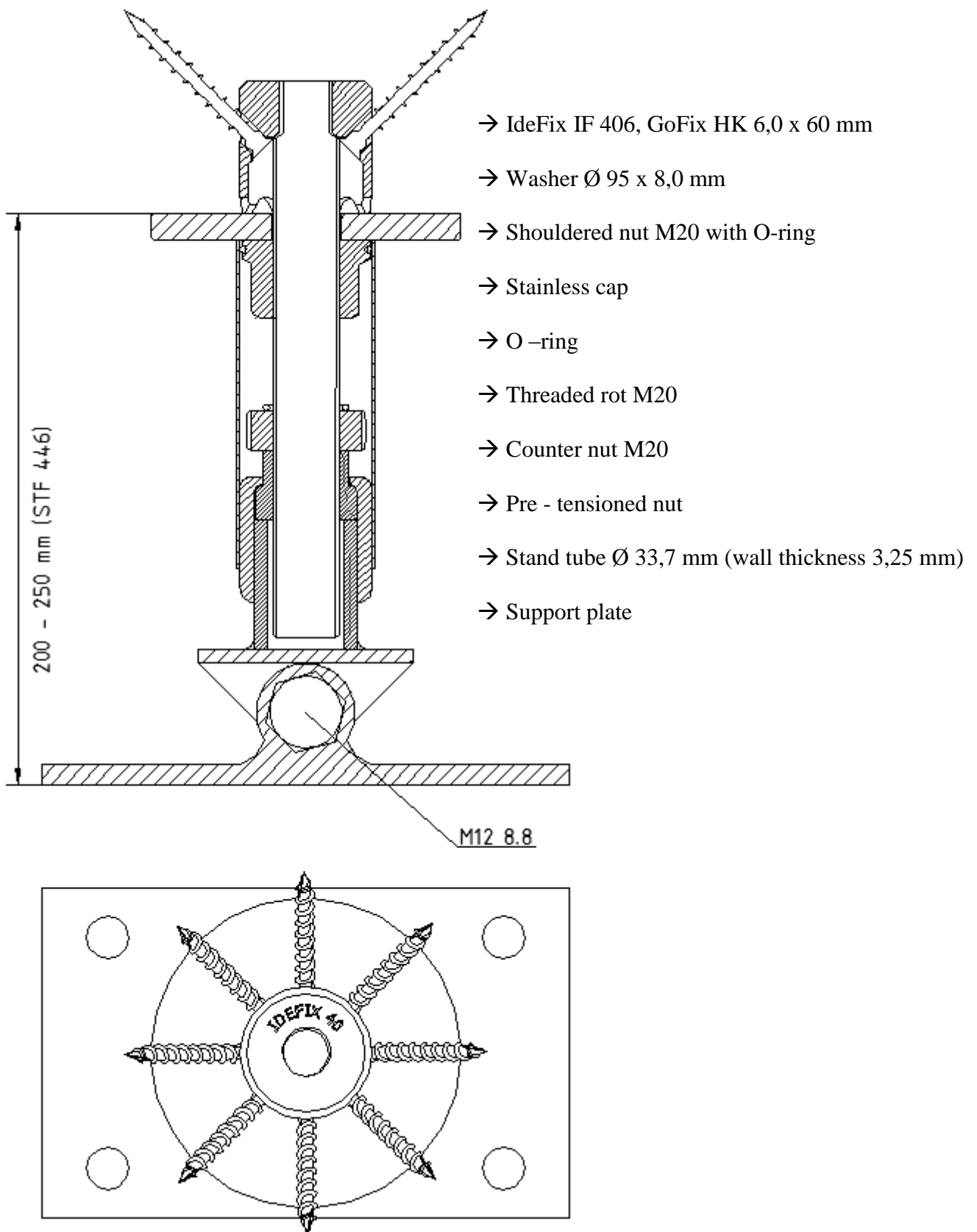

Figure 30: STF /STZ 446 with IdeFix IF or ZaFix ZF

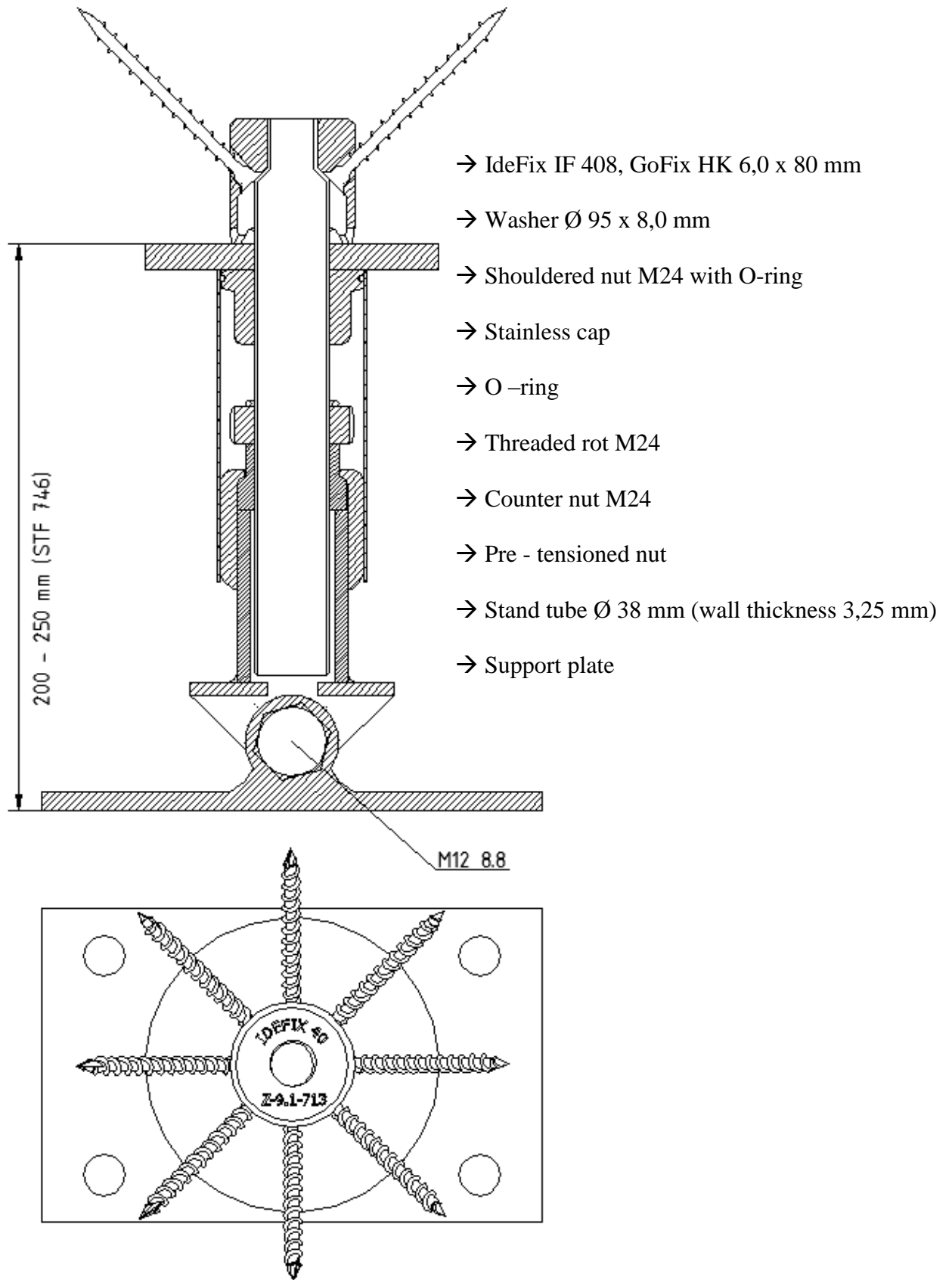

Figure 31: STF /STZ 746 with IdeFix IF or ZaFix ZF

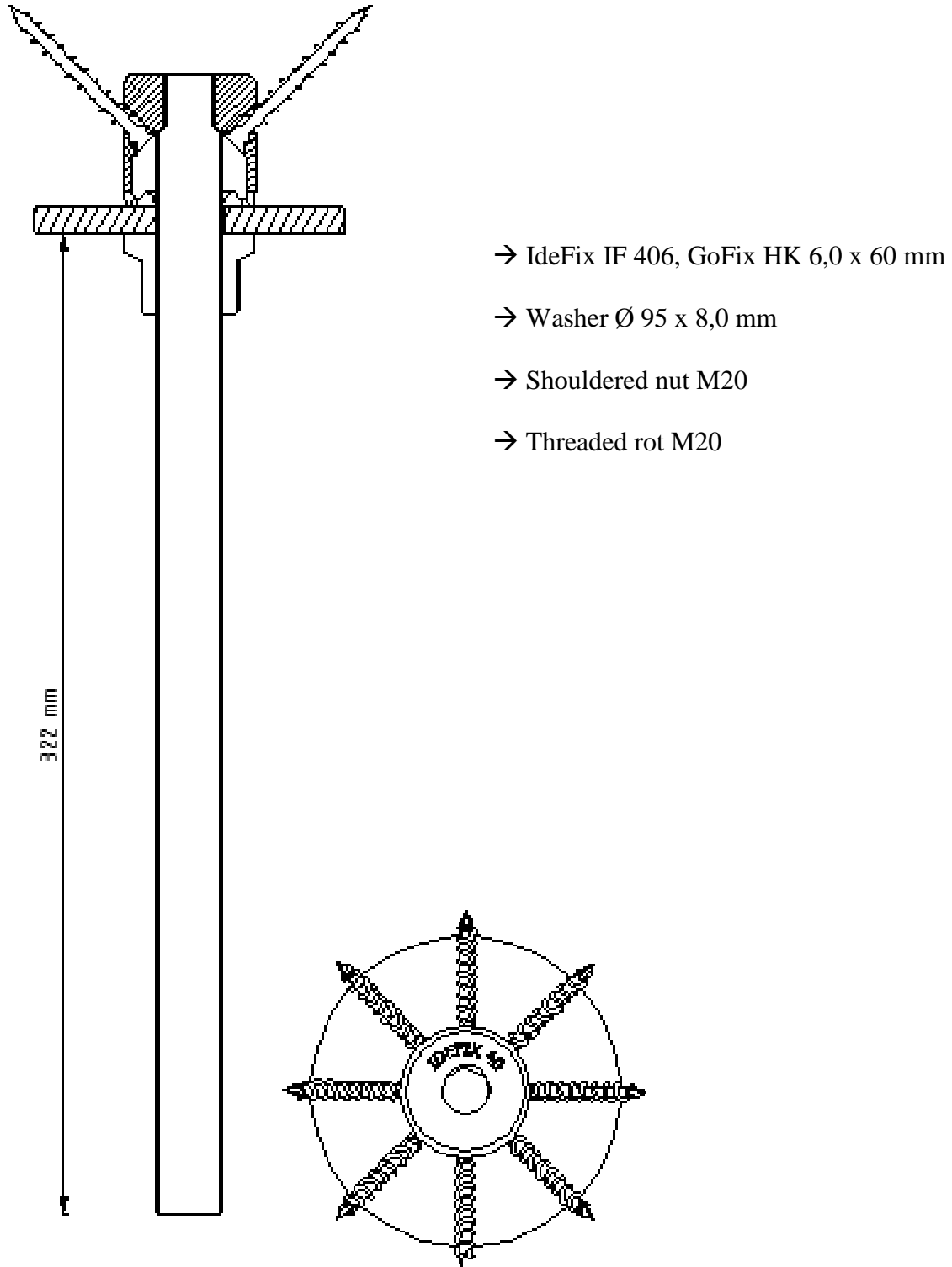

Figure 32: STF 448 with IdeFix IF

→ IdeFix IF 408, GoFix HK 6,0 x 80 mm

→ Washer Ø 95 x 8,0 mm

→ Shouldered nut M24

→ Threaded rot M24

Figure 33: STF 748 with IdeFix IF

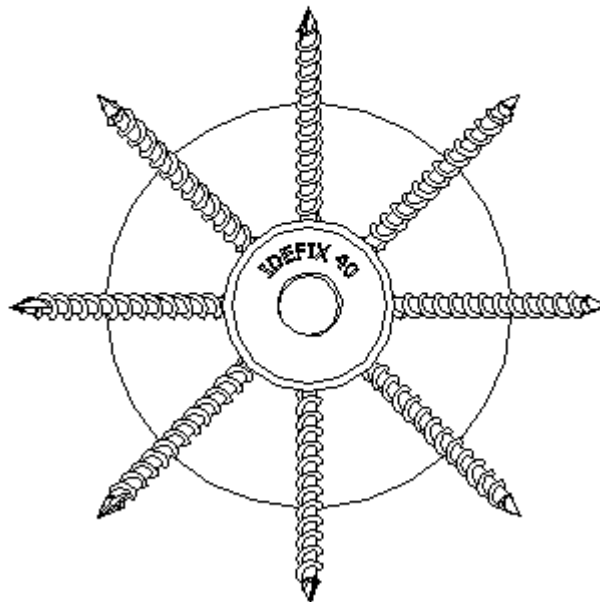
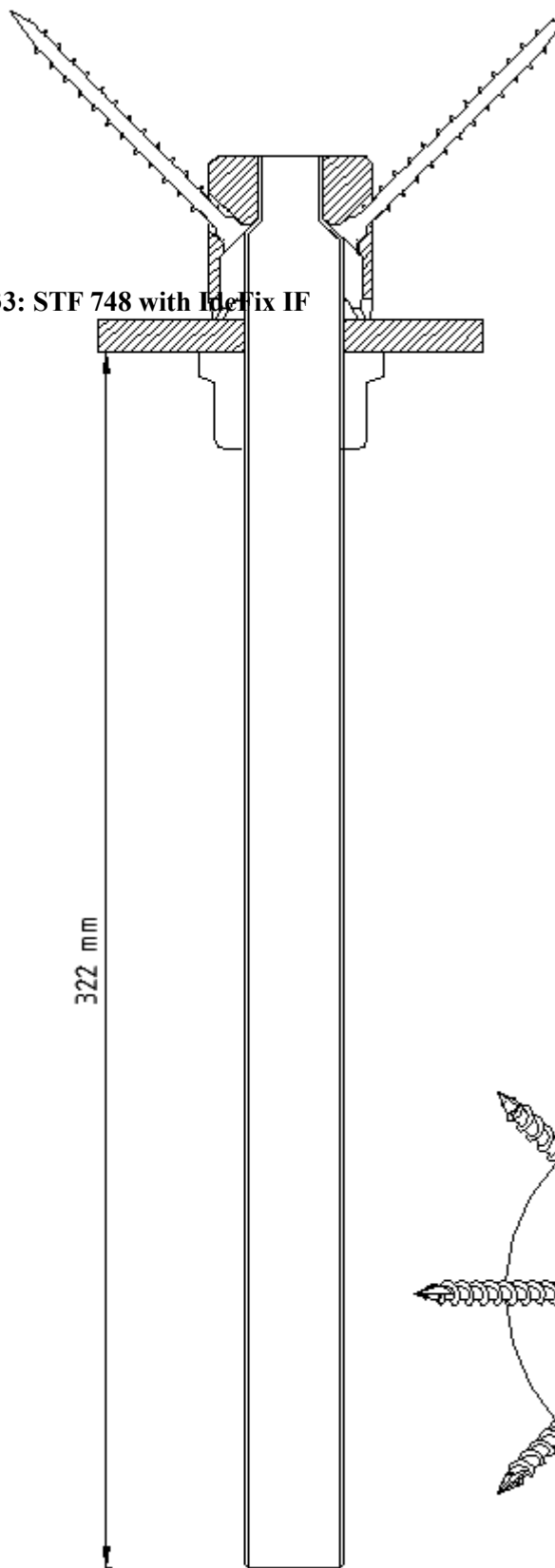

Figu

